



AiP74LVC/LVCH16T245
16-bit Dual Supply Translating Transceiver;
3-state

Product Specification

Specification Revision History:

Version	Date	Description
2017-12-A1	2017-12	New
2023-04-B1	2023-04	Update the template



Contents

1、 General Description.....	3
2、 Block Diagram And Pin Description	5
2.1、 Block Diagram	5
2.2、 Pin Configurations.....	6
2.3、 Pin Description	6
2.4、 Function Table.....	7
3、 Electrical Parameter	7
3.1、 Absolute Maximum Ratings.....	7
3.2、 Recommended Operating Conditions	8
3.3、 Electrical Characteristics	8
3.3.1、 DC Characteristics 1	8
3.3.2、 DC Characteristics 2	9
3.3.3、 DC Characteristics 3	11
3.3.4、 DC Characteristics 1	14
3.3.5、 DC Characteristics 2	15
4、 Testing Circuit	16
4.1、 AC Testing Waveforms.....	16
4.2、 Measurement Points	16
4.3、 AC Testing Circuit	17
4.4、 Test Data	17
5、 Characteristic Curve.....	18
6、 Package Information	24
6.1、 SSOP48	24
6.2、 TSSOP48.....	25
7、 Statements And Notes	26
7.1、 The name and content of Hazardous substances or Elements in the product.....	26
7.2、 Notes	26



1、 General Description

The AiP74LVC/LVCH16T245 are 16-bit dual supply translating transceivers with 3-state outputs that enable bidirectional level translation. The device can be used as two 8-bit transceivers or as a 16-bit transceiver. It has dual supplies ($V_{CC(A)}$ and $V_{CC(B)}$) for voltage translation and four 8-bit input-output ports (nAn and nBn) each with its own output enable (\overline{nOE}) and send/receive ($nDIR$) input for direction control. Both $V_{CC(A)}$ and $V_{CC(B)}$ can be supplied at any voltage between 1.2V and 5.5V making the device suitable for translating between any of the low voltage nodes (1.2V, 1.5V, 1.8V, 2.5V, 3.3V and 5.0V).

Pins nAn , \overline{nOE} and $nDIR$ are referenced to $V_{CC(A)}$ and pins nBn are referenced to $V_{CC(B)}$. A HIGH on $nDIR$ allows transmission from nAn to nBn and a LOW on $nDIR$ allows transmission from nBn to nAn .

The output enable input (\overline{nOE}) can be used to disable the outputs so the buses are effectively isolated.

The devices are fully specified for partial power-down applications using I_{OFF} . The I_{OFF} circuitry disables the output, preventing any damaging backflow current through the device when it is powered down. In suspend mode when either $V_{CC(A)}$ or $V_{CC(B)}$ are at GND level, both nAn port and nBn port are in the high-impedance OFF-state.

Active bus hold circuitry in the AiP74LVCH16T245 holds unused or floating data inputs at a valid logic level.

Features:

- Wide supply voltage range:
 - $V_{CC(A)}$: 1.2V to 5.5V
 - $V_{CC(B)}$: 1.2V to 5.5V
- Suspend mode
- $\pm 24mA$ output drive ($V_{CC}=3.0V$)
- Inputs accept voltages up to 5.5V
- Low power consumption: 30uA maximum I_{CC}
- I_{OFF} circuitry provides partial Power-down mode operation
- Specified from $-40^{\circ}C$ to $+125^{\circ}C$
- Packaging information: SSOP48/TSSOP48

**Ordering Information:****Tube packing specifications:**

Part number	Packaging form	Marking code	Tube quantity	Boxed tube quantity	Boxed quantity	Notes
AiP74LVC16T245 VB48.TB	SSOP48	74LVC16T245	30 PCS/tube	80 tube/box	2400 PCS/box	Dimensions of plastic enclosure: 15.9mm×7.5mm Pin spacing: 0.635mm
AiP74LVCH16T245 VB48.TB	SSOP48	74LVCH16T245	30 PCS/tube	80 tube/box	2400 PCS/box	Dimensions of plastic enclosure: 15.9mm×7.5mm Pin spacing: 0.635mm
AiP74LVC16T245 TA48.TB	TSSOP48	74LVC16T245	38 PCS/tube	100 tube/box	3800 PCS/box	Dimensions of plastic enclosure: 12.5mm×6.1mm Pin spacing: 0.5mm
AiP74LVCH16T245 TA48.TB	TSSOP48	74LVCH16T245	38 PCS/tube	100 tube/box	3800 PCS/box	Dimensions of plastic enclosure: 12.5mm×6.1mm Pin spacing: 0.5mm

Reel packing specifications:

Part number	Packaging form	Marking code	Reel quantity	Boxed reel quantity	Notes
AiP74LVC16T245 VB48.TR	SSOP48	74LVC16T245	1000 PCS/reel	1000 PCS/box	Dimensions of plastic enclosure: 15.9mm×7.5mm Pin spacing: 0.635mm
AiP74LVCH16T245 VB48.TR	SSOP48	74LVCH16T245	1000 PCS/reel	1000 PCS/box	Dimensions of plastic enclosure: 15.9mm×7.5mm Pin spacing: 0.635mm
AiP74LVC16T245 TA48.TR	TSSOP48	74LVC16T245	2000 PCS/reel	2000 PCS/box	Dimensions of plastic enclosure: 12.5mm×6.1mm Pin spacing: 0.5mm
AiP74LVCH16T245 TA48.TR	TSSOP48	74LVCH16T245	2000 PCS/reel	2000 PCS/box	Dimensions of plastic enclosure: 12.5mm×6.1mm Pin spacing: 0.5mm

Note: If the physical information is inconsistent with the ordering information, please refer to the actual product.



2、Block Diagram And Pin Description

2.1、Block Diagram

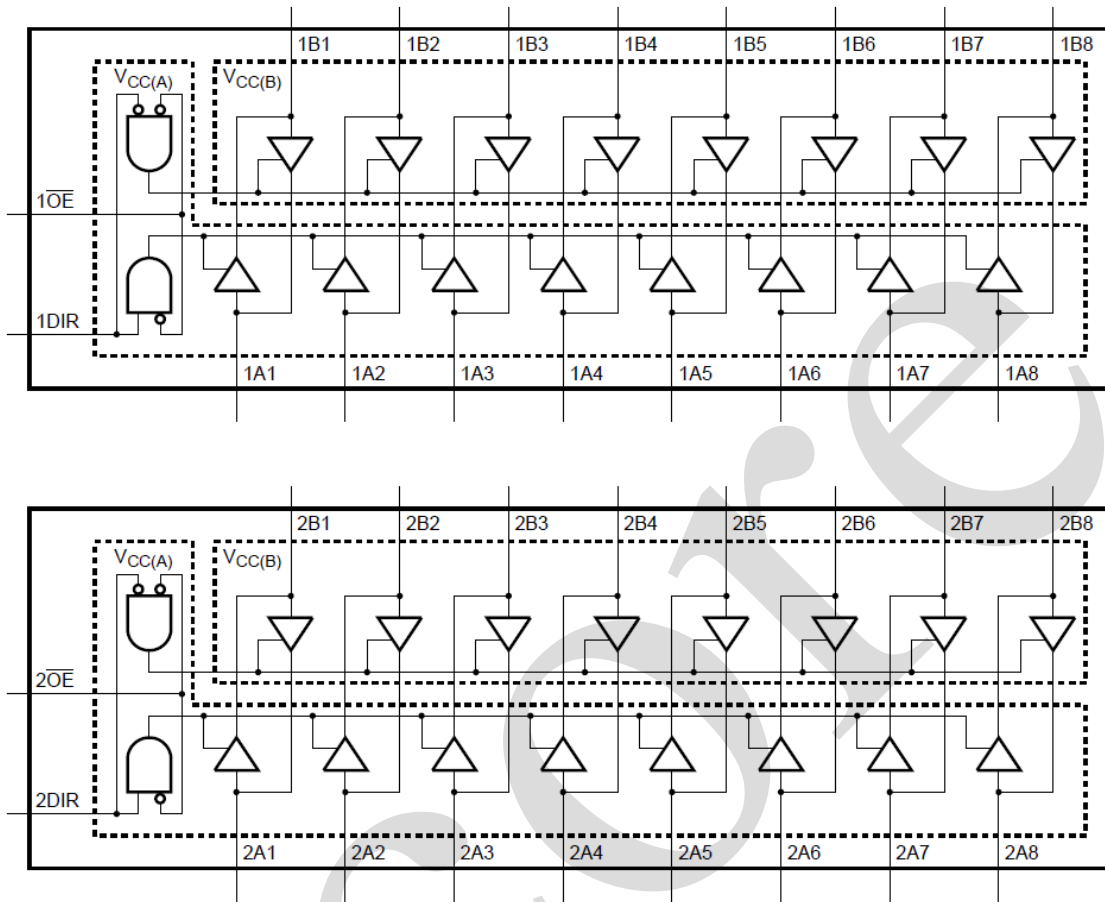

Figure 1. Logic symbol

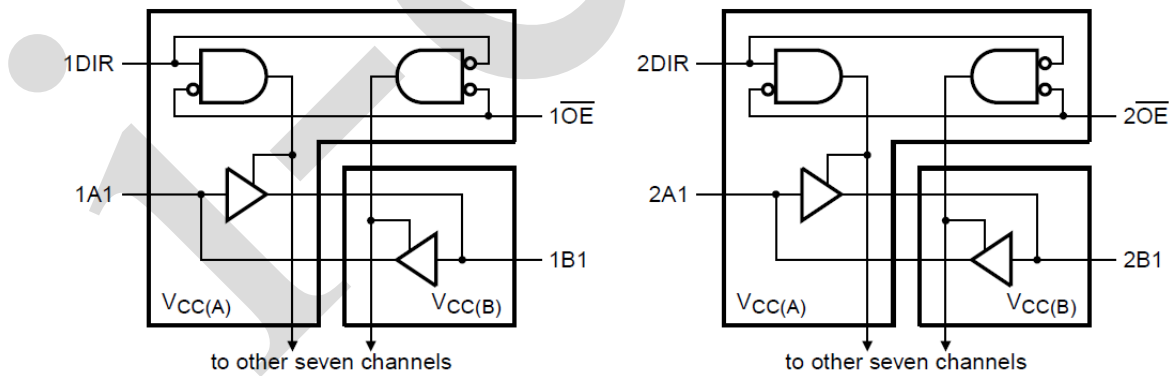
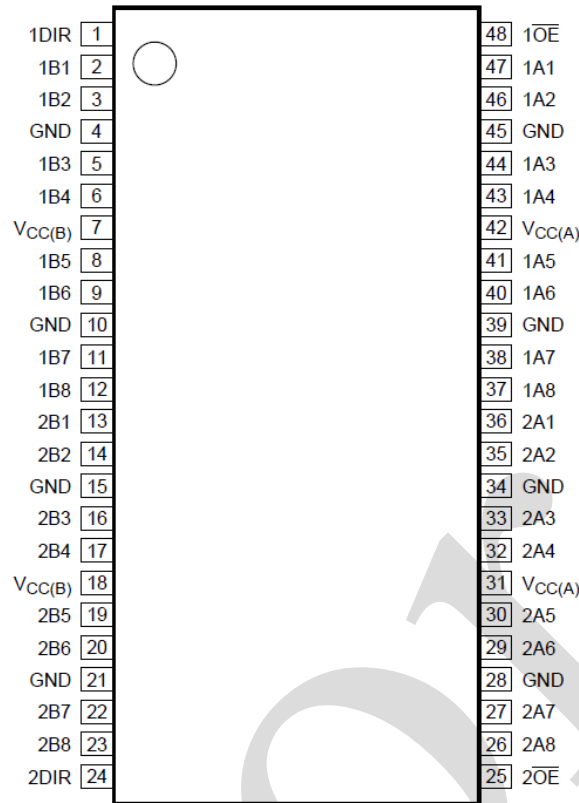

Figure 2. Logic diagram



2.2、Pin Configurations



2.3、Pin Description

Pin No.	Pin Name	Description
1,24	1DIR,2 DIR	direction control
2,3,5,6,8,9,11,12	1B1,1B2,1B3,1B4,1B5,1B6,1B7,1B8	data input or output
13,14,16,17,19,20,22, 23	2B1,2B2,2B3,2B4,2B5,2B6,2B7,2B8	data input or output
4,10,15,21,28,34,39,45	GND ^[1]	ground (0V)
7,18	V _{CC(B)}	supply voltage B (nBn inputs/outputs are referenced to V _{CC(B)})
48,25	1OE,2OE	output enable input (active LOW)
47,46,44,43,41,40,38,37	1A1,1A2,1A3,1A4,1A5,1A6,1A7,1A8	data input or output
36,35,33,32,30,29,27,26	2A1,2A2,2A3,2A4,2A5,2A6,2A7,2A8	data input or output
31,42	V _{CC(A)}	supply voltage A (nAn inputs/outputs,nOE and nDIR inputs are referenced to V _{CC(A)})

Note:[1] All GND pins must be connected to ground (0V).



2.4、Function Table

Supply voltage	Input		Input/output	
	$\overline{\text{nOE}}$	nDIR	nAn	nBn
$V_{CC(A)}, V_{CC(B)}$	L	L	nAn=nBn	input
1.2V to 5.5V	L	H	input	nBn=nAn
1.2V to 5.5V	H	X	Z	Z
GND	X	X	Z	Z

Note:

- [1] H=HIGH voltage level; L=LOW voltage level; X=don't care; Z=high-impedance OFF-state.
- [2] The nAn inputs/outputs, nDIR and $\overline{\text{nOE}}$ input circuit is referenced to $V_{CC(A)}$; The nBn inputs/outputs circuit is referenced to $V_{CC(B)}$.
- [3] If at least one of $V_{CC(A)}$ or $V_{CC(B)}$ is at GND level, the device goes into suspend mode.

3、Electrical Parameter

3.1、Absolute Maximum Ratings

(Voltages are referenced to GND(ground=0V), unless otherwise specified.)

Parameter	Symbol	Conditions	Min.	Max.	Unit
supply voltage A	$V_{CC(A)}$	-	-0.5	+6.5	V
supply voltage B	$V_{CC(B)}$	-	-0.5	+6.5	V
input clamping current	I_{IK}	$V_I < 0V$	-50	-	mA
input voltage	V_I	- ^[1]	-0.5	+6.5	V
output clamping current	I_{OK}	$V_O < 0V$	-50	-	mA
output voltage	V_O	Active mode ^{[1][2][3]}	-0.5	$V_{CCO}+0.5$	V
		Suspend or 3-state mode ^[1]	-0.5	+6.5	V
output current	I_O	$V_O=0V$ to V_{CCO} ^[2]	-	± 50	mA
supply current	I_{CC}	$I_{CC(A)}$ or $I_{CC(B)}$; per V_{CC} pin	-	100	mA
ground current	I_{GND}	per GND pin	-100	-	mA
storage temperature	T_{stg}	-	-65	+150	°C
total power dissipation	P_{tot}	-	-	500	mW
Soldering temperature	T_L	10s	260		°C

Note:

- [1] The minimum input voltage ratings and output voltage ratings may be exceeded if the input and output current ratings are observed.
- [2] V_{CCO} is the supply voltage associated with the output port.
- [3] $V_{CCO}+0.5V$ should not exceed 6.5V.



3.2、Recommended Operating Conditions

Parameter	Symbol	Conditions	Min.	Typ.	Max.	Unit
supply voltage A	$V_{CC(A)}$	-	1.2	-	5.5	V
supply voltage B	$V_{CC(B)}$	-	1.2	-	5.5	V
input voltage	V_I	-	0	-	5.5	V
output voltage	V_O	Active mode ^[1]	0	-	V_{CCO}	V
		Suspend or 3-state mode	0	-	5.5	V
ambient temperature	T_{amb}	-	-40	-	+125	°C
input transition rise and fall rate	$\Delta t/\Delta V$	$V_{CCI}=1.2V^{[2]}$	-	-	20	ns/V
		$V_{CCI}=1.4V$ to $1.95V$	-	-	20	ns/V
		$V_{CCI}=2.3V$ to $2.7V$	-	-	20	ns/V
		$V_{CCI}=3.0V$ to $3.6V$	-	-	10	ns/V
		$V_{CCI}=4.5V$ to $5.5V$	-	-	5	ns/V

Note:

[1] V_{CCO} is the supply voltage associated with the output port.

[2] V_{CCI} is the supply voltage associated with the input port.

3.3、Electrical Characteristics

3.3.1、DC Characteristics 1

($T_{amb}=25^{\circ}C$, voltages are referenced to GND (ground=0V), unless otherwise specified.)

Parameter	Symbol	Conditions	Min.	Typ.	Max.	Unit
HIGH-level output voltage	V_{OH}	$V_I=V_{IH}$ or $V_{IL}^{[1]}$ $I_O=-3mA$; $V_{CCO}=1.2V$	-	1.09	-	V
LOW-level output voltage	V_{OL}	$V_I=V_{IH}$ or V_{IL} $I_O=3mA$; $V_{CCO}=1.2V^{[1]}$	-	0.07	-	V
input leakage current	I_I	nDIR, nOE input; $V_I=0V$ to $5.5V$; $V_{CCI}=1.2V$ to $5.5V^{[2]}$	-	-	± 1	μA
bus hold LOW current	I_{BHL}	A or B port; $V_I=0.42V$; $V_{CCI}=1.2V^{[2]}$	-	19	-	μA
bus hold HIGH current	I_{BHH}	A or B port; $V_I=0.78V$; $V_{CCI}=1.2V^{[2]}$	-	-19	-	μA
bus hold LOW overdrive current	I_{BHLO}	A or B port; $V_{CCI}=1.2V^{[2][3]}$	-	19	-	μA
bus hold HIGH overdrive current	I_{BHHO}	A or B port; $V_{CCI}=1.2V^{[2][3]}$	-	-19	-	μA
OFF-state output current	I_{OZ}	A or B port; $V_O=0V$ or V_{CCO} ; $V_{CCO}=1.2V$ to $5.5V^{[1]}$	-	-	± 1	μA
		suspend mode A port; $V_O=0V$ or V_{CCO} ; $V_{CC(A)}=5.5V$; $V_{CC(B)}=0V^{[1]}$	-	-	± 1	μA
		suspend mode B port; $V_O=0V$ or V_{CCO} ; $V_{CC(A)}=0V$; $V_{CC(B)}=5.5V^{[1]}$	-	-	± 1	μA
power-off leakage current	I_{OFF}	A port; V_I or $V_O=0V$ to $5.5V$; $V_{CC(A)}=0V$; $V_{CC(B)}=1.2V$ to $5.5V$	-	-	± 1	μA
		B port; V_I or $V_O=0V$ to $5.5V$; $V_{CC(B)}=0V$; $V_{CC(A)}=1.2V$ to $5.5V$	-	-	± 1	μA



input capacitance	C_I	nDIR, n $\overline{\text{OE}}$ input; $V_I=0\text{V}$ or 3.3V ; $V_{CC(A)}=3.3\text{V}$	-	3	-	pF
input/output capacitance	$C_{I/O}$	A and B port; $V_O=3.3\text{V}$ or 0V ; $V_{CC(A)}=V_{CC(B)}=3.3\text{V}$	-	6.5	-	pF

Note:

[1] V_{CCO} is the supply voltage associated with the output port.

[2] V_{CCI} is the supply voltage associated with the data input port.

[3] To guarantee the node switches, an external driver must source/sink at least I_{BHLO}/I_{BHHO} when the input is in the range V_{IL} to V_{IH} .

3.3.2、DC Characteristics 2

($T_{amb}=-40^\circ\text{C}$ to $+85^\circ\text{C}$, voltages are referenced to GND (ground=0V), unless otherwise specified.)

Parameter	Symbol	Conditions	Min.	Typ.	Max.	Unit	
HIGH-level input voltage	V_{IH}	data input ^[1]	$V_{CCI}=1.2\text{V}$	$0.8V_{CCI}$	-	-	V
			$V_{CCI}=1.4\text{V}$ to 1.95V	$0.65V_{CCI}$	-	-	V
			$V_{CCI}=2.3\text{V}$ to 2.7V	1.7	-	-	V
			$V_{CCI}=3.0\text{V}$ to 3.6V	2.0	-	-	V
			$V_{CCI}=4.5\text{V}$ to 5.5V	$0.7V_{CCI}$	-	-	V
		nDIR, n $\overline{\text{OE}}$ input	$V_{CCI}=1.2\text{V}$	$0.8V_{CC(A)}$	-	-	V
			$V_{CCI}=1.4\text{V}$ to 1.95V	$0.65V_{CC(A)}$	-	-	V
			$V_{CCI}=2.3\text{V}$ to 2.7V	1.7	-	-	V
			$V_{CCI}=3.0\text{V}$ to 3.6V	2.0	-	-	V
			$V_{CCI}=4.5\text{V}$ to 5.5V	$0.7V_{CC(A)}$	-	-	V
LOW-level input voltage	V_{IL}	data input ^[1]	$V_{CCI}=1.2\text{V}$	-	-	$0.2V_{CCI}$	V
			$V_{CCI}=1.4\text{V}$ to 1.95V	-	-	$0.35V_{CCI}$	V
			$V_{CCI}=2.3\text{V}$ to 2.7V	-	-	0.7	V
			$V_{CCI}=3.0\text{V}$ to 3.6V	-	-	0.8	V
			$V_{CCI}=4.5\text{V}$ to 5.5V	-	-	$0.3V_{CCI}$	V
		nDIR, n $\overline{\text{OE}}$ input	$V_{CCI}=1.2\text{V}$	-	-	$0.2V_{CC(A)}$	V
			$V_{CCI}=1.4\text{V}$ to 1.95V	-	-	$0.35V_{CC(A)}$	V
			$V_{CCI}=2.3\text{V}$ to 2.7V	-	-	0.7	V
			$V_{CCI}=3.0\text{V}$ to 3.6V	-	-	0.8	V
			$V_{CCI}=4.5\text{V}$ to 5.5V	-	-	$0.3V_{CC(A)}$	V
HIGH-level output voltage	V_{OH}	$V_I=V_{IH}$	$I_O=-100\mu\text{A}$; $V_{CCO}=1.2\text{V}$ to $4.5\text{V}^{[2]}$	$V_{CCO}-0.1$	-	-	V
			$I_O=-6\text{mA}$; $V_{CCO}=1.4\text{V}$	1.0	-	-	V
			$I_O=-8\text{mA}$; $V_{CCO}=1.65\text{V}$	1.2	-	-	V
			$I_O=-12\text{mA}$; $V_{CCO}=2.3\text{V}$	1.9	-	-	V
			$I_O=-24\text{mA}$; $V_{CCO}=3.0\text{V}$	2.4	-	-	V
			$I_O=-32\text{mA}$; $V_{CCO}=4.5\text{V}$	3.8	-	-	V
LOW-level output voltage	V_{OL}	$V_I=V_{IL}^{[2]}$	$I_O=100\mu\text{A}$; $V_{CCO}=1.2\text{V}$ to 4.5V	-	-	0.1	V
			$I_O=6\text{mA}$; $V_{CCO}=1.4\text{V}$	-	-	0.3	V



			$I_O=8mA; V_{CCO}=1.65V$	-	-	0.45	V
			$I_O=12mA; V_{CCO}=2.3V$	-	-	0.3	V
			$I_O=24mA; V_{CCO}=3.0V$	-	-	0.55	V
			$I_O=32mA; V_{CCO}=4.5V$	-	-	0.55	V
input leakage current	I_I	nDIR, nOE input; $V_I=0V$ or $5.5V$; $V_{CCI}=1.2V$ to $5.5V$		-	-	± 2	μA
bus hold LOW current	I_{BHL}	A or B port ^[1]	$V_I=0.49V; V_{CCI}=1.4V$	15	-	-	μA
			$V_I=0.58V; V_{CCI}=1.65V$	25	-	-	μA
			$V_I=0.70V; V_{CCI}=2.3V$	45	-	-	μA
			$V_I=0.80V; V_{CCI}=3.0V$	100	-	-	μA
bus hold HIGH current	I_{BHH}	A or B port ^[1]	$V_I=1.35V; V_{CCI}=4.5V$	100	-	-	μA
			$V_I=0.91V; V_{CCI}=1.4V$	-15	-	-	μA
			$V_I=1.07V; V_{CCI}=1.65V$	-25	-	-	μA
			$V_I=1.70V; V_{CCI}=2.3V$	-45	-	-	μA
bus hold LOW overdrive current	I_{BHLO}	A or B port ^{[1][3]}	$V_I=2.00V; V_{CCI}=3.0V$	-100	-	-	μA
			$V_I=3.15V; V_{CCI}=4.5V$	-100	-	-	μA
			$V_{CCI}=1.6V$	125	-	-	μA
			$V_{CCI}=1.95V$	200	-	-	μA
bus hold HIGH overdrive current	I_{BHHO}	A or B port ^{[1][3]}	$V_{CCI}=2.7V$	300	-	-	μA
			$V_{CCI}=3.6V$	500	-	-	μA
			$V_{CCI}=5.5V$	900	-	-	μA
			$V_{CCI}=1.6V$	-125	-	-	μA
			$V_{CCI}=1.95V$	-200	-	-	μA
			$V_{CCI}=2.7V$	-300	-	-	μA
			$V_{CCI}=3.6V$	-500	-	-	μA
			$V_{CCI}=5.5V$	-900	-	-	μA
OFF-state output current	I_{OZ}	A or B port; $V_O=0V$ or V_{CCO} ; $V_{CCO}=1.2V$ to $5.5V$ ^[2]		-	-	± 2	μA
		suspend mode A port; $V_O=0V$ or V_{CCO} ; $V_{CC(A)}=5.5V$; $V_{CC(B)}=0V$ ^[2]		-	-	± 2	μA
		suspend mode B port; $V_O=0V$ or V_{CCO} ; $V_{CC(A)}=0V$; $V_{CC(B)}=5.5V$ ^[2]		-	-	± 2	μA
power-off leakage current	I_{OFF}	A port; V_I or $V_O=0V$ to $5.5V$; $V_{CC(A)}=0V$; $V_{CC(B)}=1.2V$ to $5.5V$		-	-	± 2	μA
		B port; V_I or $V_O=0V$ to $5.5V$; $V_{CC(B)}=0V$; $V_{CC(A)}=1.2V$ to $5.5V$		-	-	± 2	μA
supply current	I_{CC}	A port; $V_I=0V$ or V_{CCI} ; $I_O=0A$ ^[1]	$V_{CC(A)}, V_{CC(B)}=1.2V$ to $5.5V$	-	-	15	μA
			$V_{CC(A)}=5.5V; V_{CC(B)}=0V$	-	-	15	μA
			$V_{CC(A)}=0V; V_{CC(B)}=5.5V$	-2	-	-	μA
		B port; $V_I=0V$ or V_{CCI} ; $I_O=0A$	$V_{CC(A)}, V_{CC(B)}=1.2V$ to $5.5V$	-	-	15	μA
			$V_{CC(B)}=0V; V_{CC(A)}=5.5V$	-2	-	-	μA



			$V_{CC(B)}=5.5V; V_{CC(A)}=0V$	-	-	15	uA
		A plus B port ($I_{CC(A)}+I_{CC(B)}$); $I_O=0A$; $V_I=0V$ or V_{CCI}	$V_{CC(A)}, V_{CC(B)}=1.2V$ to 5.5V	-	-	25	uA
additional supply current	ΔI_{CC}	per input; $V_{CC(A)}, V_{CC(B)}=$ 3.0V to 5.5V	nDIR and nOE input; nDIR or nOE input at $V_{CC(A)}-0.6V$; A port at $V_{CC(A)}$ or GND; B port=open	-	-	50	uA
			A port; A port at $V_{CC(A)}-0.6V$; DIR at $V_{CC(A)}$; B port=open ^[4]	-	-	50	uA
			B port; B port at $V_{CC(B)}-0.6V$; nDIR at GND; A port=open ^[4]	-	-	50	uA

Note:

[1] V_{CCI} is the supply voltage associated with the data input port.

[2] V_{CCO} is the supply voltage associated with the output port.

[3] To guarantee the node switches, an external driver must source/sink at least I_{BHLO}/I_{BHHO} when the input is in the range V_{IL} to V_{IH} .

[4] For non bus hold parts only (AiP74LVC16T245).

3.3.3、DC Characteristics 3

($T_{amb}=-40^{\circ}C$ to $+125^{\circ}C$, voltages are referenced to GND (ground=0V), unless otherwise specified.)

Parameter	Symbol	Conditions	Min.	Typ.	Max.	Unit	
HIGH-level input voltage	V_{IH}	data input ^[1]	$V_{CCI}=1.2V$	0.8 V_{CCI}	-	-	V
			$V_{CCI}=1.4V$ to 1.95V	0.65 V_{CCI}	-	-	V
			$V_{CCI}=2.3V$ to 2.7V	1.7	-	-	V
			$V_{CCI}=3.0V$ to 3.6V	2.0	-	-	V
			$V_{CCI}=4.5V$ to 5.5V	0.7 V_{CCI}	-	-	V
		nDIR, nOE input	$V_{CCI}=1.2V$	0.8 $V_{CC(A)}$	-	-	V
			$V_{CCI}=1.4V$ to 1.95V	0.65 $V_{CC(A)}$	-	-	V
			$V_{CCI}=2.3V$ to 2.7V	1.7	-	-	V
			$V_{CCI}=3.0V$ to 3.6V	2.0	-	-	V
			$V_{CCI}=4.5V$ to 5.5V	0.7 $V_{CC(A)}$	-	-	V
LOW-level input voltage	V_{IL}	data input ^[1]	$V_{CCI}=1.2V$	-	-	0.2 V_{CCI}	V
			$V_{CCI}=1.4V$ to 1.95V	-	-	0.35 V_{CCI}	V
			$V_{CCI}=2.3V$ to 2.7V	-	-	0.7	V
			$V_{CCI}=3.0V$ to 3.6V	-	-	0.8	V
			$V_{CCI}=4.5V$ to 5.5V	-	-	0.3 V_{CCI}	V
		nDIR, nOE input	$V_{CCI}=1.2V$	-	-	0.2 $V_{CC(A)}$	V
			$V_{CCI}=1.4V$ to 1.95V	-	-	0.35 $V_{CC(A)}$	V
			$V_{CCI}=2.3V$ to 2.7V	-	-	0.7	V



			$V_{CCI}=3.0V$ to $3.6V$	-	-	0.8	V
			$V_{CCI}=4.5V$ to $5.5V$	-	-	$0.3V_{CC(A)}$	V
HIGH-level output voltage	V_{OH}	$V_I=V_{IH}$	$I_O=-100\mu A$; $V_{CCO}=1.2V$ to $4.5V^{[2]}$	$V_{CCO}-0.1$	-	-	V
			$I_O=-6mA$; $V_{CCO}=1.4V$	1.0	-	-	V
			$I_O=-8mA$; $V_{CCO}=1.65V$	1.2	-	-	V
			$I_O=-12mA$; $V_{CCO}=2.3V$	1.9	-	-	V
			$I_O=-24mA$; $V_{CCO}=3.0V$	2.4	-	-	V
			$I_O=-32mA$; $V_{CCO}=4.5V$	3.8	-	-	V
LOW-level output voltage	V_{OL}	$V_I=V_{IL}^{[2]}$	$I_O=100\mu A$; $V_{CCO}=1.2V$ to $4.5V$	-	-	0.1	V
			$I_O=6mA$; $V_{CCO}=1.4V$	-	-	0.3	V
			$I_O=8mA$; $V_{CCO}=1.65V$	-	-	0.45	V
			$I_O=12mA$; $V_{CCO}=2.3V$	-	-	0.3	V
			$I_O=24mA$; $V_{CCO}=3.0V$	-	-	0.55	V
			$I_O=32mA$; $V_{CCO}=4.5V$	-	-	0.55	V
input leakage current	I_I	nDIR, nOE input; $V_I=0V$ or $5.5V$; $V_{CCI}=1.2V$ to $5.5V$		-	-	± 10	μA
bus hold LOW current	I_{BHL}	A or B port ^[1]	$V_I=0.49V$; $V_{CCI}=1.4V$	10	-	-	μA
			$V_I=0.58V$; $V_{CCI}=1.65V$	20	-	-	μA
			$V_I=0.70V$; $V_{CCI}=2.3V$	45	-	-	μA
			$V_I=0.80V$; $V_{CCI}=3.0V$	80	-	-	μA
			$V_I=1.35V$; $V_{CCI}=4.5V$	100	-	-	μA
bus hold HIGH current	I_{BHH}	A or B port ^[1]	$V_I=0.91V$; $V_{CCI}=1.4V$	-10	-	-	μA
			$V_I=1.07V$; $V_{CCI}=1.65V$	-20	-	-	μA
			$V_I=1.70V$; $V_{CCI}=2.3V$	-45	-	-	μA
			$V_I=2.00V$; $V_{CCI}=3.0V$	-80	-	-	μA
			$V_I=3.15V$; $V_{CCI}=4.5V$	-100	-	-	μA
bus hold LOW overdrive current	I_{BHLO}	A or B port ^{[1][3]}	$V_{CCI}=1.6V$	125	-	-	μA
			$V_{CCI}=1.95V$	200	-	-	μA
			$V_{CCI}=2.7V$	300	-	-	μA
			$V_{CCI}=3.6V$	500	-	-	μA
			$V_{CCI}=5.5V$	900	-	-	μA
bus hold HIGH overdrive current	I_{BHHO}	A or B port ^{[1][3]}	$V_{CCI}=1.6V$	-125	-	-	μA
			$V_{CCI}=1.95V$	-200	-	-	μA
			$V_{CCI}=2.7V$	-300	-	-	μA
			$V_{CCI}=3.6V$	-500	-	-	μA
			$V_{CCI}=5.5V$	-900	-	-	μA
OFF-state output current	I_{OZ}	A or B port; $V_O=0V$ or V_{CCO} ; $V_{CCO}=1.2V$ to $5.5V^{[2]}$		-	-	± 10	μA
		suspend mode A port; $V_O=0V$ or V_{CCO} ; $V_{CC(A)}=5.5V$; $V_{CC(B)}=0V^{[2]}$		-	-	± 10	μA



		suspend mode B port; $V_O=0V$ or V_{CCO} ; $V_{CC(A)}=0V$; $V_{CC(B)}=5.5V^{[2]}$	-	-	± 10	μA	
power-off leakage current	I_{OFF}	A port; V_I or $V_O=0V$ to $5.5V$; $V_{CC(A)}=0V$; $V_{CC(B)}=1.2V$ to $5.5V$	-	-	± 10	μA	
		B port; V_I or $V_O=0V$ to $5.5V$; $V_{CC(B)}=0V$; $V_{CC(A)}=1.2V$ to $5.5V$	-	-	± 10	μA	
supply current	I_{CC}	A port; $V_I=0V$ or V_{CCI} ; $I_O=0A^{[1]}$	$V_{CC(A)}, V_{CC(B)}=1.2V$ to $5.5V$	-	-	20	μA
			$V_{CC(A)}=5.5V$; $V_{CC(B)}=0V$	-	-	20	μA
			$V_{CC(A)}=0V$; $V_{CC(B)}=5.5V$	-4	-	-	μA
		B port; $V_I=0V$ or V_{CCI} ; $I_O=0A$	$V_{CC(A)}, V_{CC(B)}=1.2V$ to $5.5V$	-	-	20	μA
			$V_{CC(B)}=0V$; $V_{CC(A)}=5.5V$	-4	-	-	μA
			$V_{CC(B)}=5.5V$; $V_{CC(A)}=0V$	-	-	20	μA
A plus B port ($I_{CC(A)}+I_{CC(B)}$); $I_O=0A$; $V_I=0V$ or V_{CCI}	$V_{CC(A)}, V_{CC(B)}=1.2V$ to $5.5V$	-	-	30	μA		
additional supply current	ΔI_{CC}	per input; $V_{CC(A)}, V_{CC(B)}=3.0V$ to $5.5V$	nDIR and nOE input; nDIR or nOE input at $V_{CC(A)}-0.6V$; A port at $V_{CC(A)}$ or GND; B port=open	-	-	75	μA
			A port; A port at $V_{CC(A)}-0.6V$; DIR at $V_{CC(A)}$; B port=open ^[4]	-	-	75	μA
			B port; B port at $V_{CC(B)}-0.6V$; nDIR at GND; A port=open ^[4]	-	-	75	μA

Note:

[1] V_{CCI} is the supply voltage associated with the data input port.

[2] V_{CCO} is the supply voltage associated with the output port.

[3] To guarantee the node switches, an external driver must source/sink at least I_{BHLO}/I_{BHHO} when the input is in the range V_{IL} to V_{IH} .

[4] For non bus hold parts only (AiP74LVC16T245).



3.3.4、DC Characteristics 1

($T_{amb} = -40^{\circ}\text{C}$ to $+85^{\circ}\text{C}$, voltages are referenced to GND (ground=0V), unless otherwise specified.)

Parameter	Symbol	Conditions	$V_{CC(B)}$										Unit
			1.5V±0.1V		1.8V±0.15V		2.5V±0.2V		3.3V±0.3V		5.0V±0.5V		
			Min.	Max.	Min.	Max.	Min.	Max.	Min.	Max.	Min.	Max.	
$V_{CC(A)}=1.5V\pm0.1V$													
propagation delay	t_{PLH}, t_{PHL}	nAn to nBn	-	17.6	-	15.3	-	13.1	-	12.5	-	12.5	ns
		nBn to nAn	-	17.5	-	16.3	-	15.2	-	14.4	-	13.8	ns
disable time	t_{PLZ}, t_{PHZ}	$\overline{\text{nOE}}$ to nAn	-	29.1	-	29.1	-	29.1	-	29.1	-	29.1	ns
		$\overline{\text{nOE}}$ to nBn	-	36.4	-	34.5	-	17.3	-	15.5	-	13.6	ns
enable time	t_{PZL}, t_{PZH}	$\overline{\text{nOE}}$ to nAn	-	33.6	-	33.6	-	33.6	-	33.6	-	33.6	ns
		$\overline{\text{nOE}}$ to nBn	-	37.3	-	35.5	-	18.2	-	15.5	-	14.5	ns
$V_{CC(A)}=1.8V\pm0.15V$													
propagation delay	t_{PLH}, t_{PHL}	nAn to nBn	-	16.4	-	13.1	-	11.1	-	10.1	-	10.0	ns
		nBn to nAn	-	15.2	-	12.7	-	11.4	-	10.6	-	10.1	ns
disable time	t_{PLZ}, t_{PHZ}	$\overline{\text{nOE}}$ to nAn	-	29.1	-	28.9	-	28.7	-	28.5	-	28.4	ns
		$\overline{\text{nOE}}$ to nBn	-	36.4	-	32.9	-	15.5	-	14.5	-	13.0	ns
enable time	t_{PZL}, t_{PZH}	$\overline{\text{nOE}}$ to nAn	-	24.5	-	24.5	-	24.4	-	24.3	-	24.3	ns
		$\overline{\text{nOE}}$ to nBn	-	35.5	-	34.5	-	18.2	-	14.2	-	13.5	ns
$V_{CC(A)}=2.5V\pm0.2V$													
propagation delay	t_{PLH}, t_{PHL}	nAn to nBn	-	15.3	-	11.9	-	9.2	-	8.2	-	7.6	ns
		nBn to nAn	-	13.0	-	10.6	-	8.9	-	7.9	-	7.1	ns
disable time	t_{PLZ}, t_{PHZ}	$\overline{\text{nOE}}$ to nAn	-	10.9	-	10.9	-	10.9	-	10.9	-	10.9	ns
		$\overline{\text{nOE}}$ to nBn	-	33.6	-	30.5	-	13.6	-	13.0	-	9.9	ns
enable time	t_{PZL}, t_{PZH}	$\overline{\text{nOE}}$ to nAn	-	15.5	-	15.5	-	15.5	-	15.5	-	15.5	ns
		$\overline{\text{nOE}}$ to nBn	-	33.6	-	29.5	-	15.9	-	12.3	-	10.0	ns
$V_{CC(A)}=3.3V\pm0.3V$													
propagation delay	t_{PLH}, t_{PHL}	nAn to nBn	-	14.6	-	11.2	-	8.1	-	7.0	-	6.5	ns
		nBn to nAn	-	12.3	-	9.8	-	7.9	-	6.8	-	6.0	ns
disable time	t_{PLZ}, t_{PHZ}	$\overline{\text{nOE}}$ to nAn	-	10.9	-	10.9	-	10.9	-	10.9	-	10.9	ns
		$\overline{\text{nOE}}$ to nBn	-	30.9	-	28.2	-	13.2	-	11.4	-	9.5	ns
enable time	t_{PZL}, t_{PZH}	$\overline{\text{nOE}}$ to nAn	-	12.3	-	12.3	-	12.1	-	12.0	-	12.0	ns
		$\overline{\text{nOE}}$ to nBn	-	33.5	-	28.5	-	16.5	-	11.3	-	9.5	ns
$V_{CC(A)}=5.0V\pm0.5V$													
propagation delay	t_{PLH}, t_{PHL}	nAn to nBn	-	14.1	-	10.6	-	7.3	-	6.3	-	5.6	ns
		nBn to nAn	-	12.3	-	9.5	-	7.4	-	6.3	-	5.5	ns
disable time	t_{PLZ}, t_{PHZ}	$\overline{\text{nOE}}$ to nAn	-	8.4	-	8.4	-	8.4	-	8.4	-	8.4	ns
		$\overline{\text{nOE}}$ to nBn	-	32.5	-	29.5	-	12.3	-	10.9	-	8.9	ns
enable time	t_{PZL}, t_{PZH}	$\overline{\text{nOE}}$ to nAn	-	9.7	-	9.7	-	9.7	-	9.7	-	9.7	ns
		$\overline{\text{nOE}}$ to nBn	-	33.5	-	28.5	-	16.7	-	12.3	-	9.7	ns



3.3.5、DC Characteristics 2

($T_{amb} = -40^{\circ}\text{C}$ to $+125^{\circ}\text{C}$, voltages are referenced to GND (ground=0V), unless otherwise specified.)

Parameter	Symbol	Conditions	$V_{CC(B)}$										Unit
			$1.5V \pm 0.1V$		$1.8V \pm 0.15V$		$2.5V \pm 0.2V$		$3.3V \pm 0.3V$		$5.0V \pm 0.5V$		
			Min.	Max.	Min.	Max.	Min.	Max.	Min.	Max.	Min.	Max.	
$V_{CC(A)} = 1.5V \pm 0.1V$													
propagation delay	t_{PLH}, t_{PHL}	nAn to nBn	-	19.4	-	16.8	-	14.4	-	13.8	-	13.8	ns
		nBn to nAn	-	19.2	-	17.9	-	16.7	-	15.8	-	15.2	ns
disable time	t_{PLZ}, t_{PHZ}	$\overline{\text{nOE}}$ to nAn	-	32	-	32	-	32	-	32	-	32	ns
		$\overline{\text{nOE}}$ to nBn	-	40	-	38	-	19	-	17	-	15	ns
enable time	t_{PZL}, t_{PZH}	$\overline{\text{nOE}}$ to nAn	-	37	-	37	-	37	-	37	-	37	ns
		$\overline{\text{nOE}}$ to nBn	-	41	-	39	-	20	-	17	-	16	ns
$V_{CC(A)} = 1.8V \pm 0.15V$													
propagation delay	t_{PLH}, t_{PHL}	nAn to nBn	-	18	-	14.4	-	12.2	-	11.1	-	11	ns
		nBn to nAn	-	16.7	-	14	-	12.5	-	11.7	-	11.1	ns
disable time	t_{PLZ}, t_{PHZ}	$\overline{\text{nOE}}$ to nAn	-	32	-	31.8	-	31.6	-	31.3	-	31.2	ns
		$\overline{\text{nOE}}$ to nBn	-	40	-	36.2	-	17.1	-	16.0	-	14.3	ns
enable time	t_{PZL}, t_{PZH}	$\overline{\text{nOE}}$ to nAn	-	27	-	27	-	26.8	-	26.7	-	26.7	ns
		$\overline{\text{nOE}}$ to nBn	-	39	-	38	-	20	-	15.6	-	14.8	ns
$V_{CC(A)} = 2.5V \pm 0.2V$													
propagation delay	t_{PLH}, t_{PHL}	nAn to nBn	-	16.8	-	13.1	-	10.1	-	9	-	8.4	ns
		nBn to nAn	-	14.3	-	11.7	-	9.8	-	8.7	-	7.8	ns
disable time	t_{PLZ}, t_{PHZ}	$\overline{\text{nOE}}$ to nAn	-	12	-	12	-	12	-	12	-	12	ns
		$\overline{\text{nOE}}$ to nBn	-	37	-	33.6	-	15	-	14.3	-	10.9	ns
enable time	t_{PZL}, t_{PZH}	$\overline{\text{nOE}}$ to nAn	-	17	-	17	-	17	-	17	-	17	ns
		$\overline{\text{nOE}}$ to nBn	-	37	-	32.5	-	17.5	-	13.5	-	11	ns
$V_{CC(A)} = 3.3V \pm 0.3V$													
propagation delay	t_{PLH}, t_{PHL}	nAn to nBn	-	16.1	-	12.3	-	8.9	-	7.7	-	7.2	ns
		nBn to nAn	-	13.5	-	10.8	-	8.7	-	7.5	-	6.6	ns
disable time	t_{PLZ}, t_{PHZ}	$\overline{\text{nOE}}$ to nAn	-	12	-	12	-	12	-	12	-	12	ns
		$\overline{\text{nOE}}$ to nBn	-	34	-	31	-	14.5	-	12.5	-	10.4	ns
enable time	t_{PZL}, t_{PZH}	$\overline{\text{nOE}}$ to nAn	-	13.5	-	13.5	-	13.3	-	13.2	-	13.2	ns
		$\overline{\text{nOE}}$ to nBn	-	36.8	-	31.4	-	18.1	-	12.4	-	10.5	ns
$V_{CC(A)} = 5.0V \pm 0.5V$													
propagation delay	t_{PLH}, t_{PHL}	nAn to nBn	-	15.5	-	11.7	-	8	-	6.9	-	6.2	ns
		nBn to nAn	-	13.5	-	10.5	-	8.1	-	6.9	-	6	ns
disable time	t_{PLZ}, t_{PHZ}	$\overline{\text{nOE}}$ to nAn	-	9.2	-	9.2	-	9.2	-	9.2	-	9.2	ns
		$\overline{\text{nOE}}$ to nBn	-	35.8	-	32.5	-	13.5	-	12	-	9.8	ns
enable time	t_{PZL}, t_{PZH}	$\overline{\text{nOE}}$ to nAn	-	10.7	-	10.7	-	10.7	-	10.7	-	10.7	ns
		$\overline{\text{nOE}}$ to nBn	-	36.8	-	31.4	-	18.4	-	13.5	-	10.7	ns



4、Testing Circuit

4.1、AC Testing Waveforms

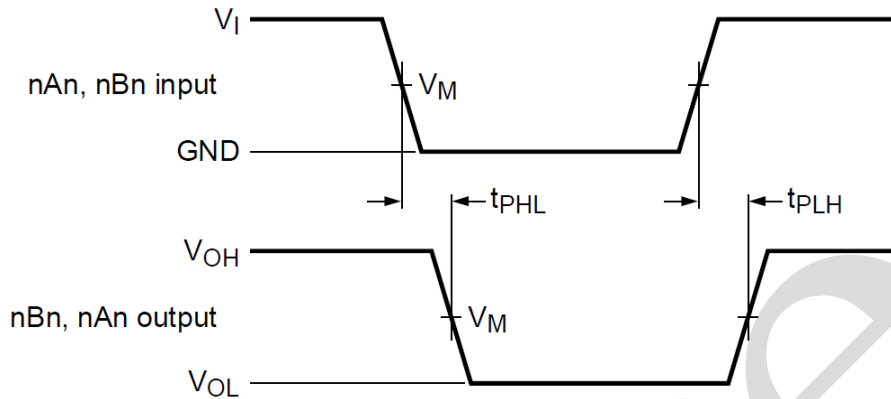

V_{OL} and V_{OH} are typical output voltage levels that occur with the output load.

Figure 3. The data input (nAn, nBn) to output (nBn, nAn) propagation delay times

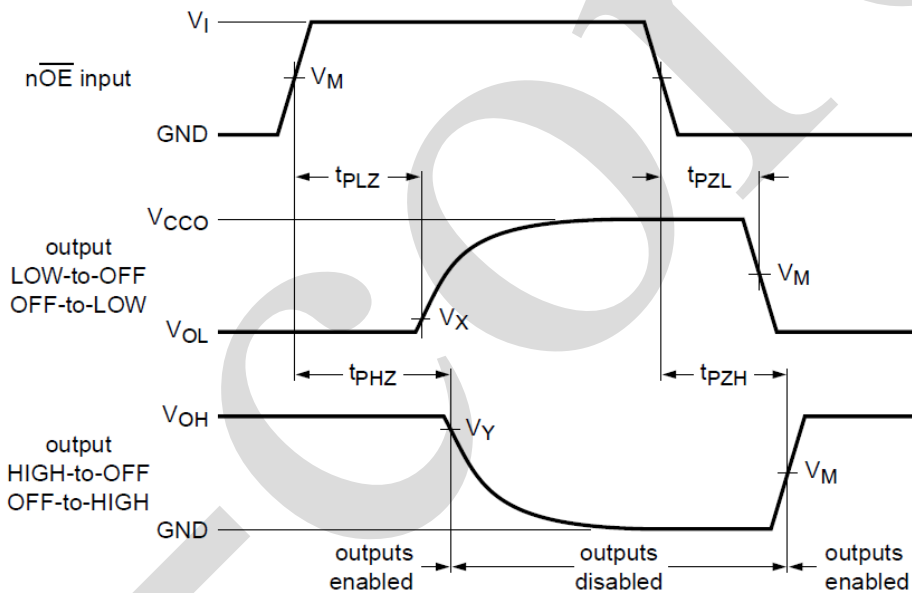

V_{OL} and V_{OH} are typical output voltage levels that occur with the output load.

Figure 4. Enable and disable times

4.2、Measurement Points

Supply voltage	Input ^[1]	Output ^[2]		
		V_M	V_X	V_Y
$V_{CC(A)}, V_{CC(B)}$ 1.2V to 1.6V	$0.5V_{CCI}$	$0.5V_{CCO}$	$V_{OL}+0.1V$	$V_{OH}-0.1V$
1.65V to 2.7V	$0.5V_{CCI}$	$0.5V_{CCO}$	$V_{OL}+0.15V$	$V_{OH}-0.15V$
3.0V to 5.5V	$0.5V_{CCI}$	$0.5V_{CCO}$	$V_{OL}+0.3V$	$V_{OH}-0.3V$

Note:

[1] V_{CCI} is the supply voltage associated with the data input port.

[2] V_{CCO} is the supply voltage associated with the output port.



4.3、 AC Testing Circuit

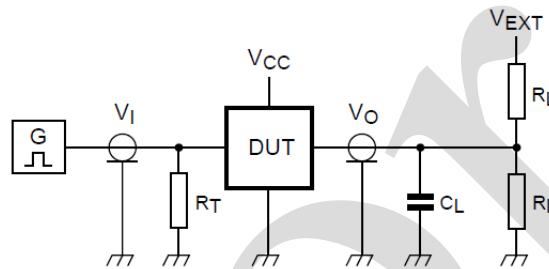
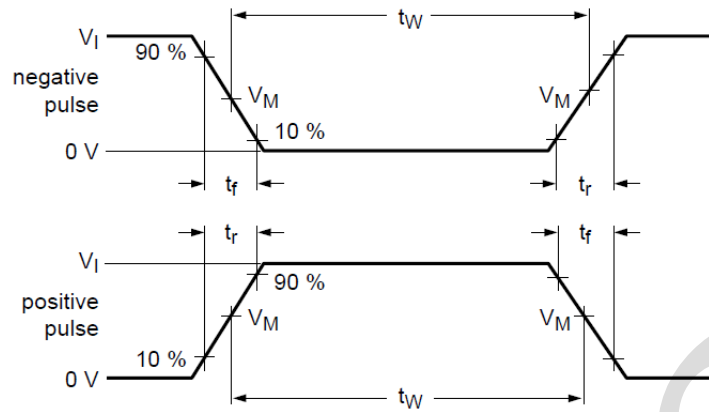

Figure 5. Load circuitry for switching times

Definitions for test circuit:

R_L =Load resistance.

C_L =Load capacitance including jig and probe capacitance.

R_T =Termination resistance.

V_{EXT} =External voltage for measuring switching times.

4.4、 Test Data

Supply voltage	Input		Load		V_{EXT}		
$V_{CC(A)}, V_{CC(B)}$	$V_I^{[1]}$	$\Delta t/\Delta V^{[2]}$	C_L	R_L	t_{PLH}, t_{PHL}	t_{PZH}, t_{PHZ}	$t_{PZL}, t_{PLZ}^{[3]}$
1.2V to 5.5V	V_{CCI}	$\leq 1.0\text{ns/V}$	15pF	2k Ω	open	GND	2V $_{CCO}$

Note:

[1] V_{CCI} is the supply voltage associated with the data input port.

[2] $dV/dt \geq 1.0\text{V/ns}$.

[3] V_{CCO} is the supply voltage associated with the output port.



5、Characteristic Curve

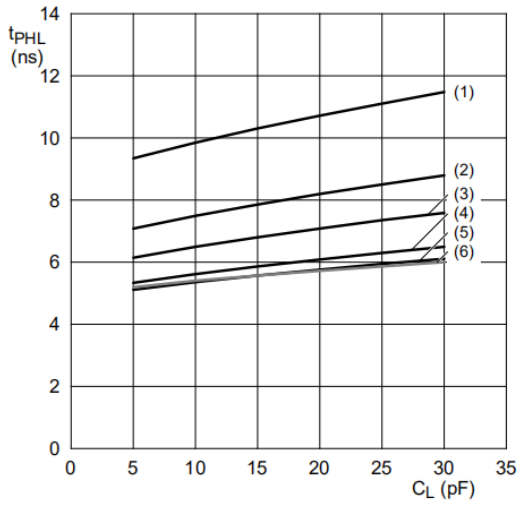

a. HIGH to LOW propagation delay (nAn to nBn)

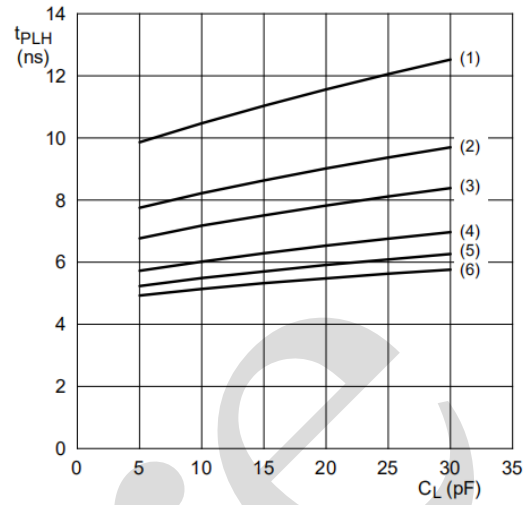

b. LOW to HIGH propagation delay (nAn to nBn)

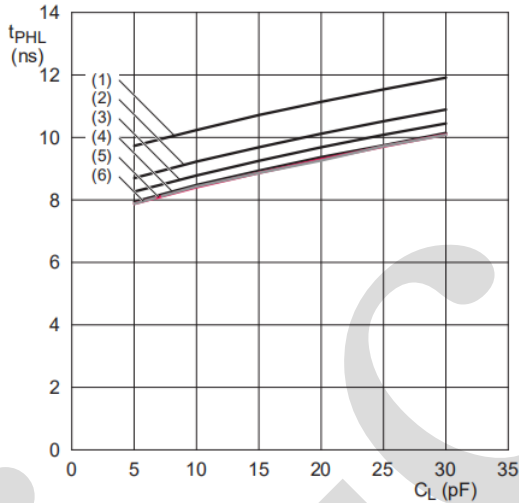

c. HIGH to LOW propagation delay (nBn to nAn)

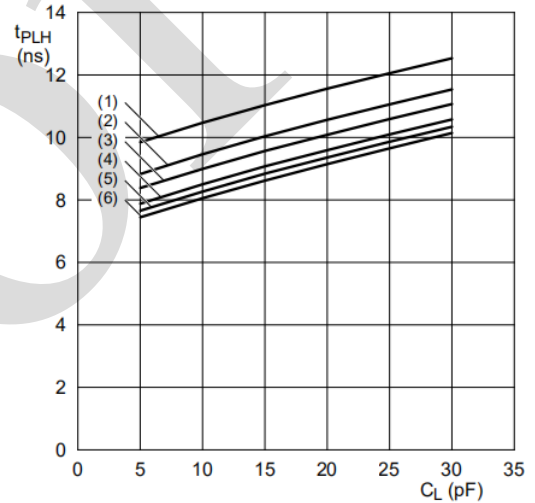

d. LOW to HIGH propagation delay (nBn to nAn)

- Note: (1) $V_{CC(B)}=1.2V$.
(2) $V_{CC(B)}=1.5V$.
(3) $V_{CC(B)}=1.8V$.
(4) $V_{CC(B)}=2.5V$.
(5) $V_{CC(B)}=3.3V$.
(6) $V_{CC(B)}=5.0V$.

Figure 6. Typical propagation delay versus load capacitance; $T_{amb}=25^{\circ}C$; $V_{CC(A)}=1.2V$

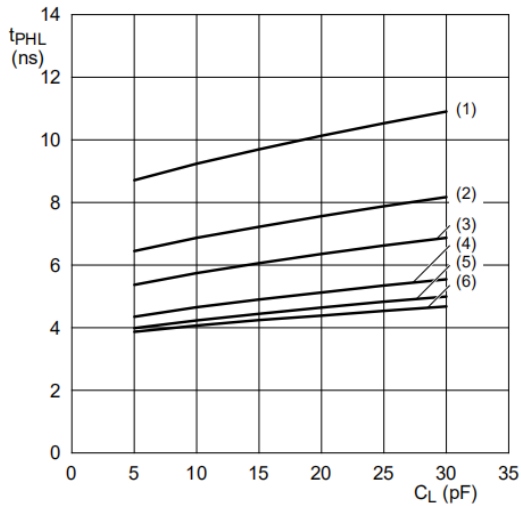

a. HIGH to LOW propagation delay (nAn to nBn)

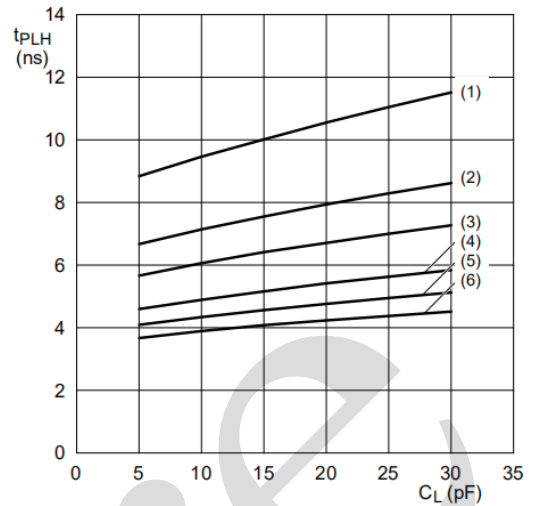

b. LOW to HIGH propagation delay (nAn to nBn)

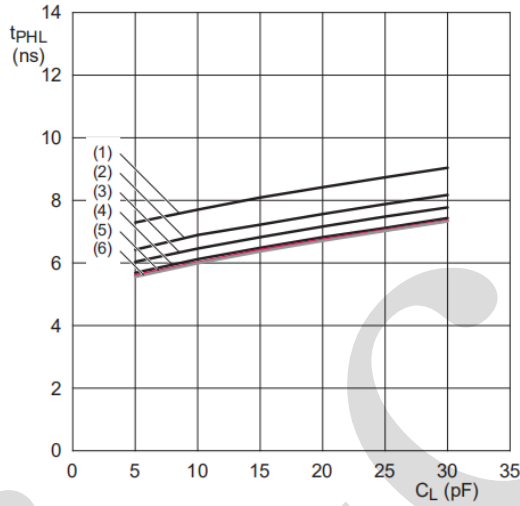

c. HIGH to LOW propagation delay (nBn to nAn)

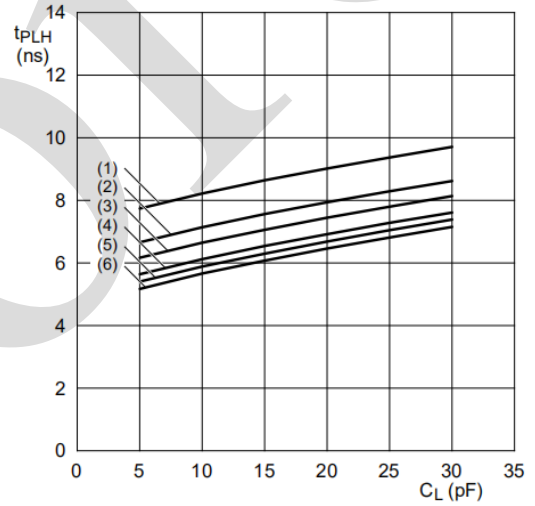

d. LOW to HIGH propagation delay (nBn to nAn)

- Note: (1) $V_{CC(B)}=1.2V$.
(2) $V_{CC(B)}=1.5V$.
(3) $V_{CC(B)}=1.8V$.
(4) $V_{CC(B)}=2.5V$.
(5) $V_{CC(B)}=3.3V$.
(6) $V_{CC(B)}=5.0V$.

Figure 7. Typical propagation delay versus load capacitance; $T_{amb}=25^{\circ}C$; $V_{CC(A)}=1.5V$

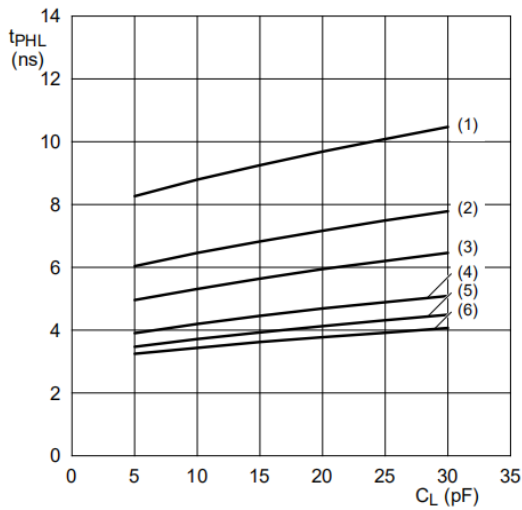

a. HIGH to LOW propagation delay (nAn to nBn)

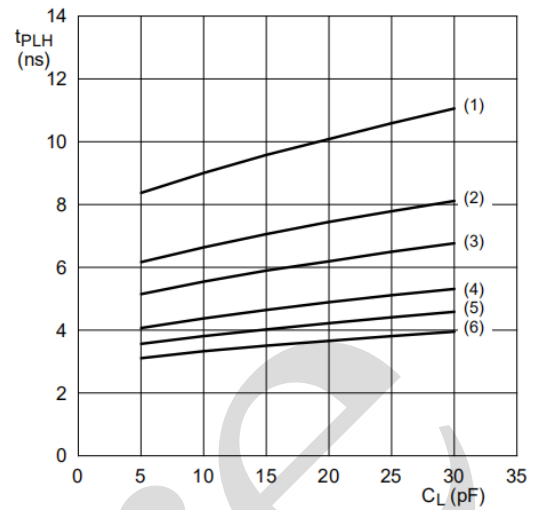

b. LOW to HIGH propagation delay (nAn to nBn)

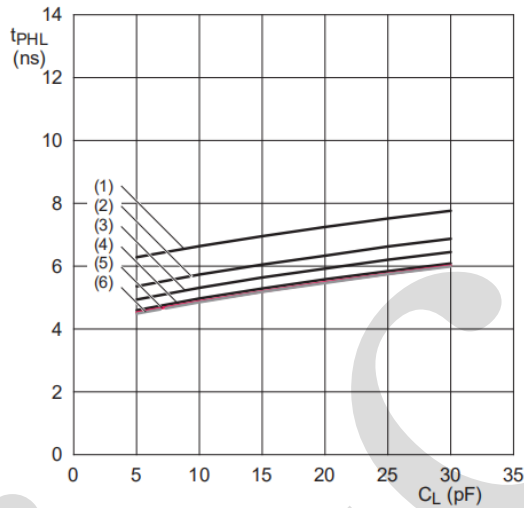

c. HIGH to LOW propagation delay (nBn to nAn)

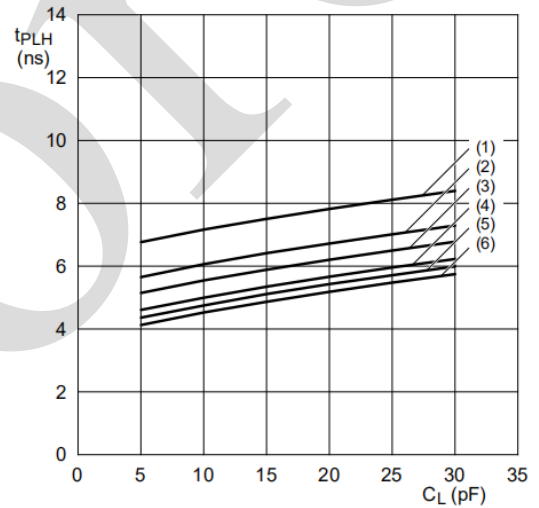

d. LOW to HIGH propagation delay (nBn to nAn)

Note: (1) $V_{CC(B)}=1.2V$.

(2) $V_{CC(B)}=1.5V$.

(3) $V_{CC(B)}=1.8V$.

(4) $V_{CC(B)}=2.5V$.

(5) $V_{CC(B)}=3.3V$.

(6) $V_{CC(B)}=5.0V$.

Figure 8. Typical propagation delay versus load capacitance; $T_{amb}=25^{\circ}C$; $V_{CC(A)}=1.8V$

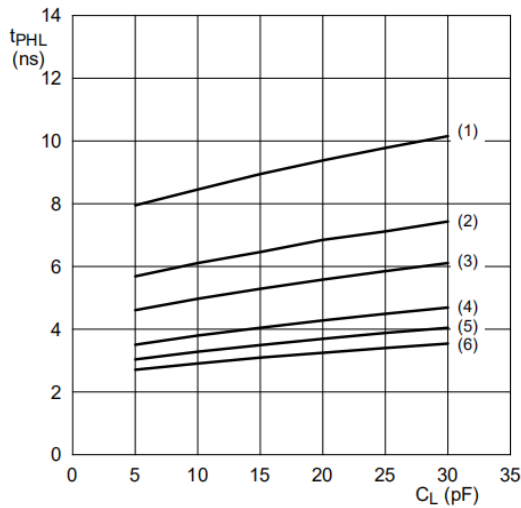

a. HIGH to LOW propagation delay (nAn to nBn)

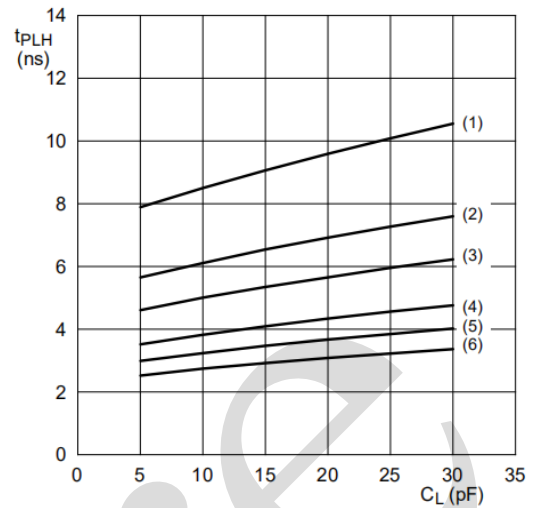

b. LOW to HIGH propagation delay (nAn to nBn)

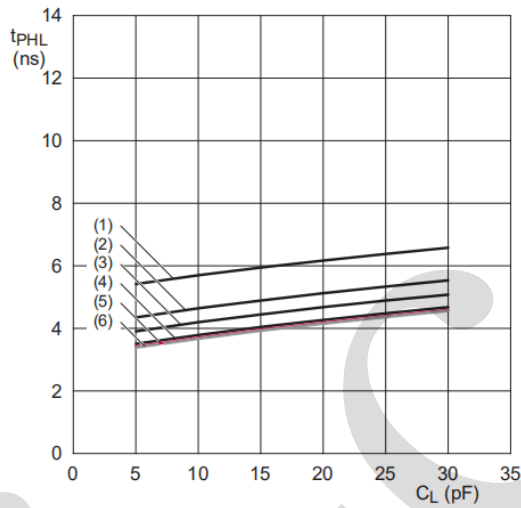

c. HIGH to LOW propagation delay (nBn to nAn)

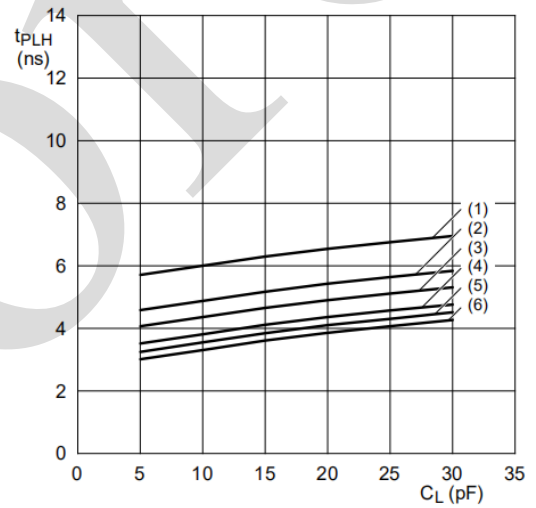

d. LOW to HIGH propagation delay (nBn to nAn)

- Note: (1) $V_{CC(B)}=1.2V$.
(2) $V_{CC(B)}=1.5V$.
(3) $V_{CC(B)}=1.8V$.
(4) $V_{CC(B)}=2.5V$.
(5) $V_{CC(B)}=3.3V$.
(6) $V_{CC(B)}=5.0V$.

Figure 9. Typical propagation delay versus load capacitance; $T_{amb}=25^{\circ}C$; $V_{CC(A)}=2.5V$

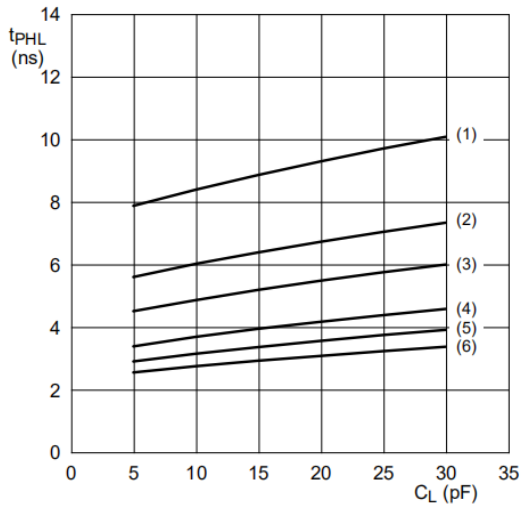

a. HIGH to LOW propagation delay (nAn to nBn)

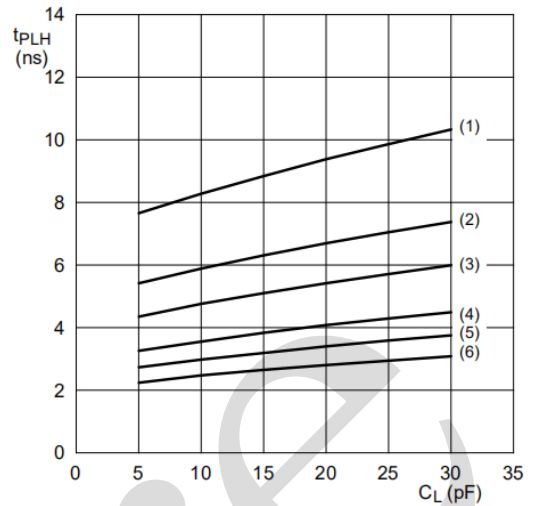

b. LOW to HIGH propagation delay (nAn to nBn)

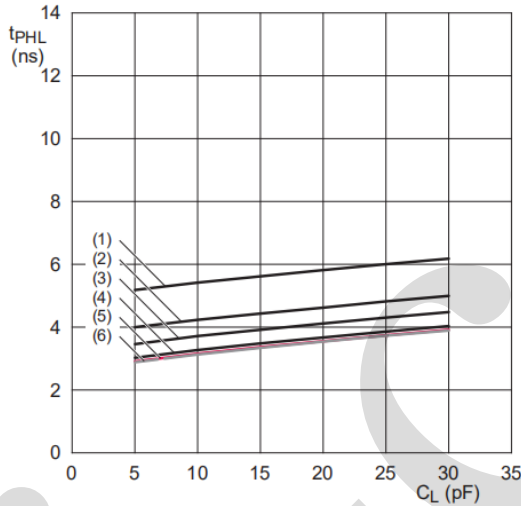

c. HIGH to LOW propagation delay (nBn to nAn)

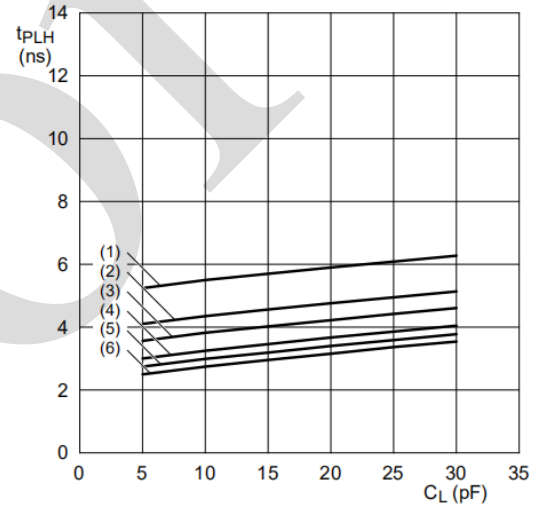

d. LOW to HIGH propagation delay (nBn to nAn)

- Note: (1) $V_{CC(B)}=1.2V$.
(2) $V_{CC(B)}=1.5V$.
(3) $V_{CC(B)}=1.8V$.
(4) $V_{CC(B)}=2.5V$.
(5) $V_{CC(B)}=3.3V$.
(6) $V_{CC(B)}=5.0V$.

Figure 10. Typical propagation delay versus load capacitance; $T_{amb}=25^{\circ}C$; $V_{CC(A)}=3.3V$

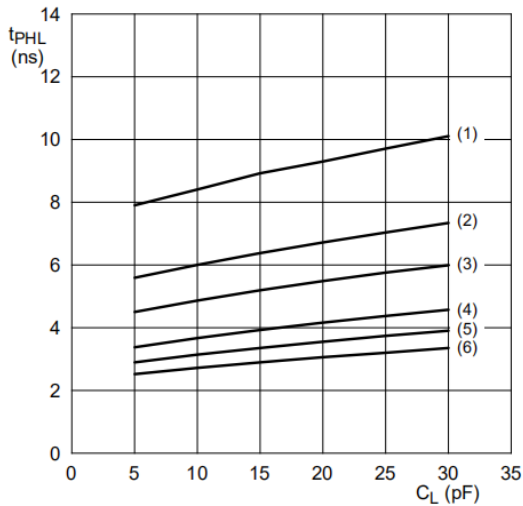

a. HIGH to LOW propagation delay (nAn to nBn)

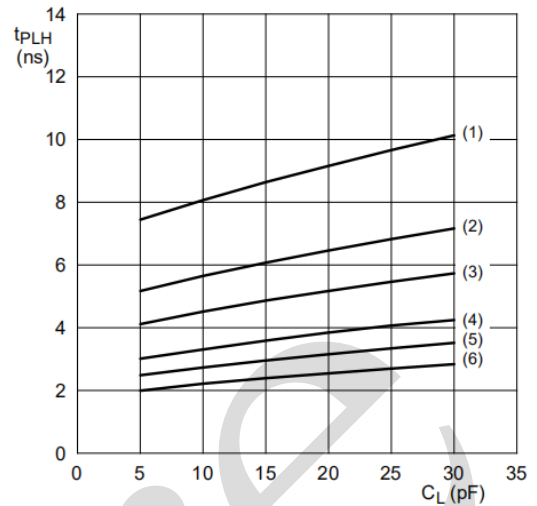

b. LOW to HIGH propagation delay (nAn to nBn)

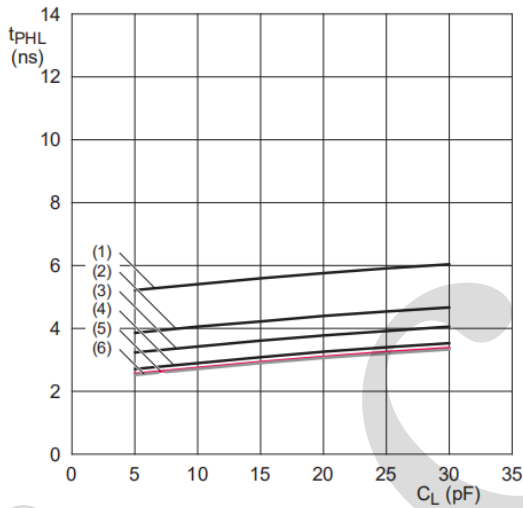

c. HIGH to LOW propagation delay (nBn to nAn)

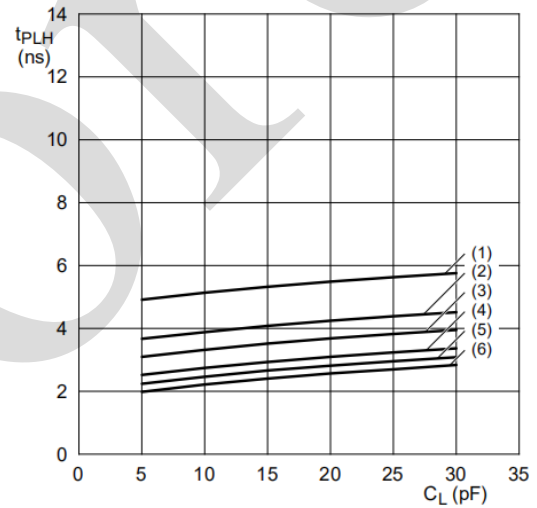

d. LOW to HIGH propagation delay (nBn to nAn)

- Note: (1) $V_{CC(B)}=1.2V$.
(2) $V_{CC(B)}=1.5V$.
(3) $V_{CC(B)}=1.8V$.
(4) $V_{CC(B)}=2.5V$.
(5) $V_{CC(B)}=3.3V$.
(6) $V_{CC(B)}=5.0V$.

Figure 11. Typical propagation delay versus load capacitance; $T_{amb}=25^{\circ}C$; $V_{CC(A)}=5.0V$



6、Package Information

6.1、SSOP48

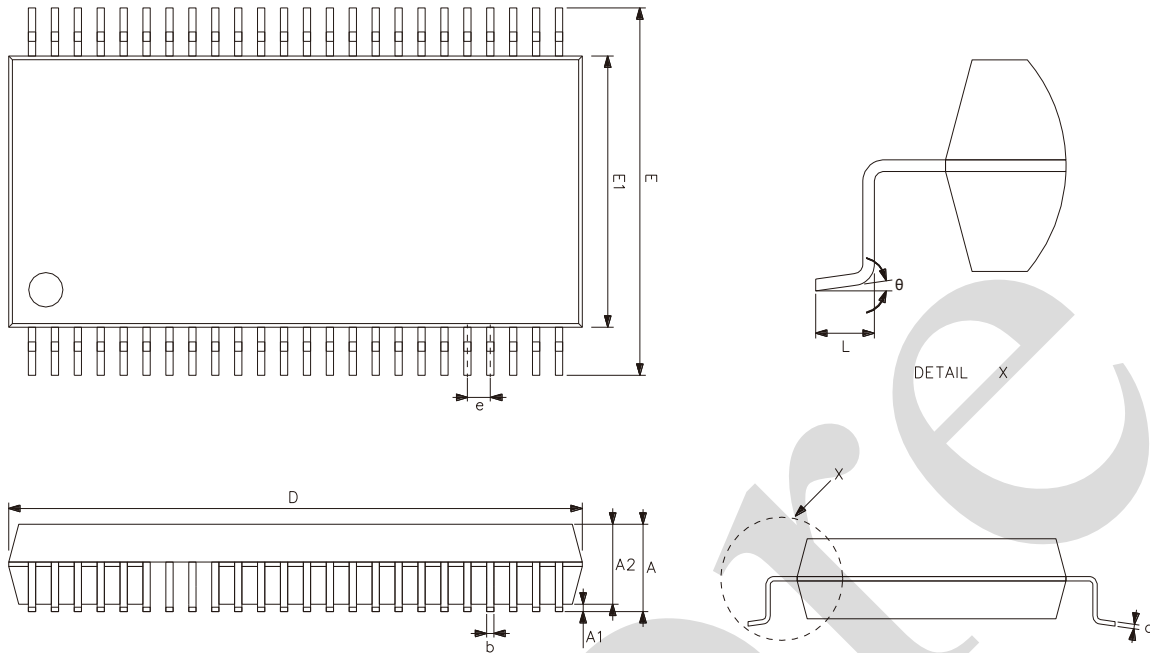

Symbol	Dimensions (mm)	
	Min.	Max.
A	-	2.85
A1	0.15	0.45
A2	2.10	2.45
b	0.20	0.35
c	0.12	0.25
D	15.60	16.05
E	9.80	10.80
E1	7.35	7.65
e	0.635	
L	0.56	0.95
θ	0°	8°



6.2、TSSOP48

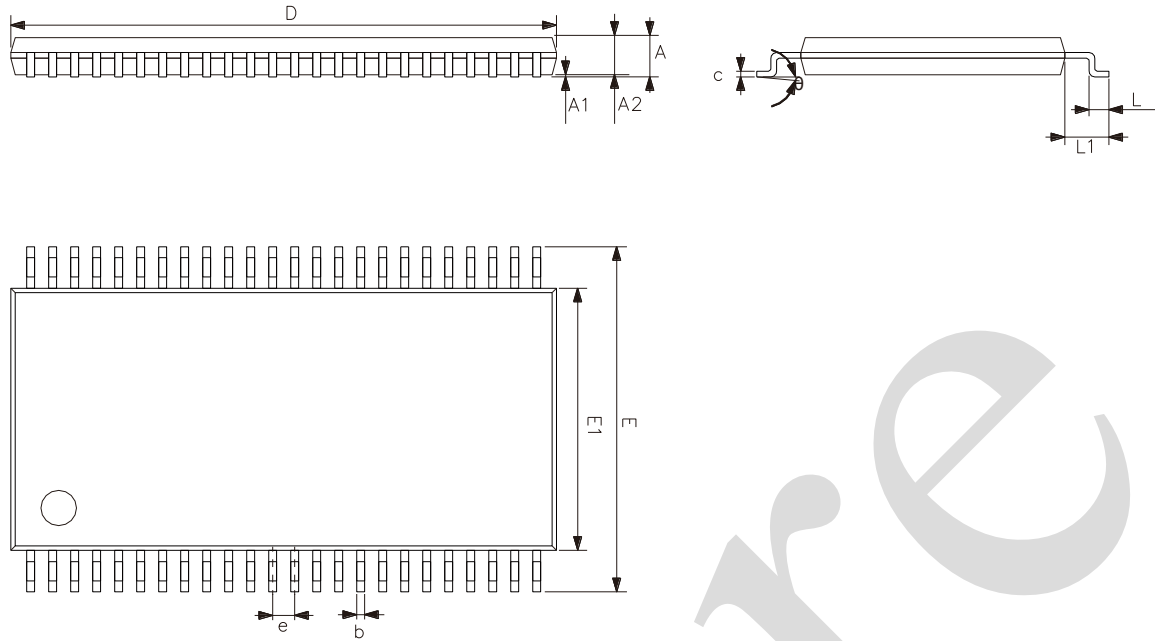

Symbol	Dimensions (mm)	
	Min.	Max.
A	-	1.20
A1	0.03	0.15
A2	0.82	1.05
b	0.17	0.27
c	0.12	0.22
D	12.40	12.60
E	7.90	8.30
E1	6.00	6.20
e	0.50	
L	0.35	0.75
L1	1.00	
θ	0°	8°



7、 Statements And Notes

7.1、 The name and content of Hazardous substances or Elements in the product

Part name	Hazardous substances or Elements									
	Lead and lead compounds	Mercury and mercury compounds	Cadmium and cadmium compounds	Hexavalent chromium compounds	Polybrominated biphenyls	Polybrominated biphenyl ethers	Dibutyl phthalate	Butylbenzyl phthalate	Di-2-ethylhexyl phthalate	Diisobutyl phthalate
Lead frame	○	○	○	○	○	○	○	○	○	○
Plastic resin	○	○	○	○	○	○	○	○	○	○
Chip	○	○	○	○	○	○	○	○	○	○
The lead	○	○	○	○	○	○	○	○	○	○
Plastic sheet installed	○	○	○	○	○	○	○	○	○	○
explanation	○: Indicates that the content of hazardous substances or elements in the detection limit of the following the SJ/T11363-2006 standard. ×: Indicates that the content of hazardous substances or elements exceeding the SJ/T11363-2006 Standard limit requirements.									

7.2、 Notes

We Recommend you to read this chapter carefully before using this product.

The information in this chapter is provided for reference only and i-Core disclaims any express or implied warranties, including but not limited to applicability, special application or non-infringement of third party rights.

This product is not suitable for critical equipment such as life-saving, life-sustaining or safety equipment. It is also not suitable for applications that may result in personal injury, death, or serious property or environmental damage due to product malfunction or failure. I-Core will not be liable for any damages incurred by the customers at their own risk for such applications.

The customer is responsible for conducting all necessary tests i-Core's application to avoid failure in the application or the application of the customer's third party users. I-Core does not accept any liability.

The Company reserves the right to change or improve the information published in this chapter at any time.

The information in this chapter are subject to change without notice. We recommend the customer to consult our sales staff before purchasing.

Please obtain related materials form i-Core's regular channels and we are not responsible for its content if it is provided by sources other than our company.

In case of any conflict between the Chinese and English version, the version is subject to the Chinese one.