



AiP74ALVC164245 16-bit Dual Supply Translating Transceiver; 3-state

Product Specification

Specification Revision History:

Version	Date	Description
2017-02-A1	2020-02	New
2023-04-B1	2023-04	Update the template
2023-11-B2	2023-11	Modify ordering information



Contents

1、 General Description.....	3
2、 Block Diagram And Pin Description	5
2.1、 Block Diagram	5
2.2、 Pin Configurations	6
2.3、 Pin Description.....	6
2.4、 Function Table	6
3、 Electrical Parameter	7
3.1、 Absolute Maximum Ratings.....	7
3.2、 Recommended Operating Conditions	7
3.3、 Electrical Characteristics.....	8
3.3.1、 DC Characteristics 1	8
3.3.2、 DC Characteristics 2.....	9
3.3.3、 AC Characteristics 1	10
3.3.4、 AC Characteristics 2.....	11
4、 Testing Circuit	12
4.1、 AC Testing Circuit.....	12
4.2、 Test Data.....	12
4.3、 AC Testing Waveforms.....	13
4.4、 Measurement points	13
5、 Package Information	14
5.1、 TSSOP48.....	14
5.2、 SSOP48.....	15
6、 Statements And Notes	16
6.1、 The name and content of Hazardous substances or Elements in the product	16
6.2、 Notes.....	16



1、 General Description

The AiP74ALVC164245 is a high-performance, low-power, low-voltage, Si-gate CMOS device, superior to most advanced CMOS compatible TTL families.

The AiP74ALVC164245 is a 16-bit (dual octal) dual supply translating transceiver featuring non-inverting 3-state bus compatible outputs in both send and receive directions. It is designed to interface between a 3V and 5V bus in a mixed 3V and 5V supply environment.

This device can be used as two 8-bit transceivers or one 16-bit transceiver.

The direction control inputs (1DIR and 2DIR) determine the direction of the data flow. nDIR (active HIGH) enables data from nAn ports to nBn ports. nDIR (active LOW) enables data from nBn ports to nAn ports.

The output enable inputs (1 $\overline{\text{OE}}$ and 2 $\overline{\text{OE}}$), when HIGH, disable both nAn and nBn ports by placing them in a high-impedance OFF-state. Pins nAn, n $\overline{\text{OE}}$ and nDIR are referenced to $V_{\text{CC(A)}}$ and pins nBn are referenced to $V_{\text{CC(B)}}$.

In suspend mode, when one of the supply voltages is zero, there will be no current flow from the non-zero supply towards the zero supply. The nAn-outputs must be set 3-state and the voltage on the A-bus must be smaller than V_{diode} (typical 0.7V). $V_{\text{CC(B)}} \geq V_{\text{CC(A)}}$ (except in suspend mode).

Features:

- 5V tolerant inputs/outputs for interfacing with 5V logic
- Wide supply voltage range:
3V port ($V_{\text{CC(A)}}$): 1.5V to 3.6V
5V port ($V_{\text{CC(B)}}$): 1.2V to 5.5V
- CMOS low power consumption
- Direct interface with TTL levels
- Control inputs voltage range from 2.7V to 5.5V
- Inputs accept voltages up to 5.5V
- High-impedance outputs when $V_{\text{CC(A)}}$ or $V_{\text{CC(B)}}=0\text{V}$
- Specified from -40°C to $+125^{\circ}\text{C}$
- Packaging information: TSSOP48/ SSOP48

**Ordering Information:****Tube packing specifications:**

Part number	Packaging form	Marking code	Tube quantity	Boxed tube quantity	Boxed quantity	Notes
AiP74ALVC164245 TA48.TB	TSSOP48	74ALVC164245	38 PCS/tube	100 tube/box	3800 PCS/box	Dimensions of plastic enclosure: 12.5mm×6.1mm Pin spacing: 0.5mm
AiP74ALVC164245 VB48.TB	SSOP48	74ALVC164245	30 PCS/tube	80 tube/box	2400 PCS/box	Dimensions of plastic enclosure: 15.9mm×7.5mm Pin spacing: 0.635mm

Reel packing specifications:

Part number	Packaging form	Marking code	Reel quantity	Boxed reel quantity	Notes
AiP74ALVC164245 TA48.TR	TSSOP48	74ALVC164245	2000 PCS/reel	2000 PCS/box	Dimensions of plastic enclosure: 12.5mm×6.1mm Pin spacing:0.5mm
AiP74ALVC164245 VB48.TR	SSOP48	74ALVC164245	1000 PCS/reel	1000 PCS/box	Dimensions of plastic enclosure: 15.9mm×7.5mm Pin spacing: 0.635mm

Note: If the physical information is inconsistent with the ordering information, please refer to the actual product.



2、Block Diagram And Pin Description

2.1、Block Diagram

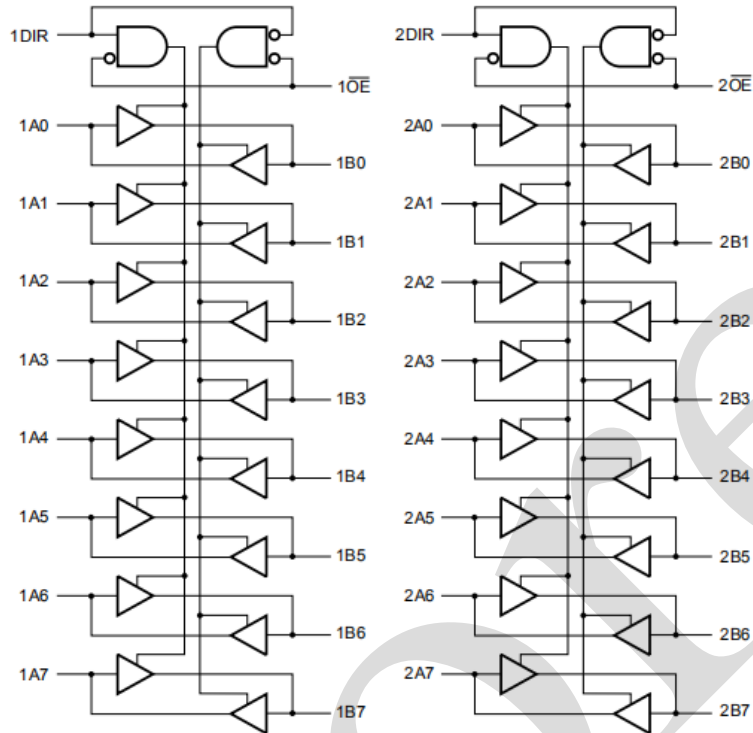

Figure 1. Logic symbol

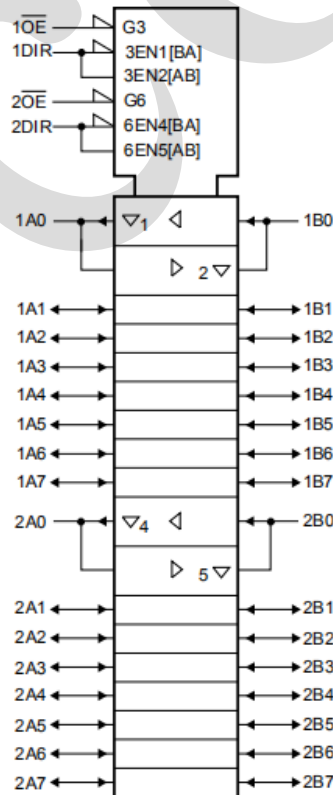
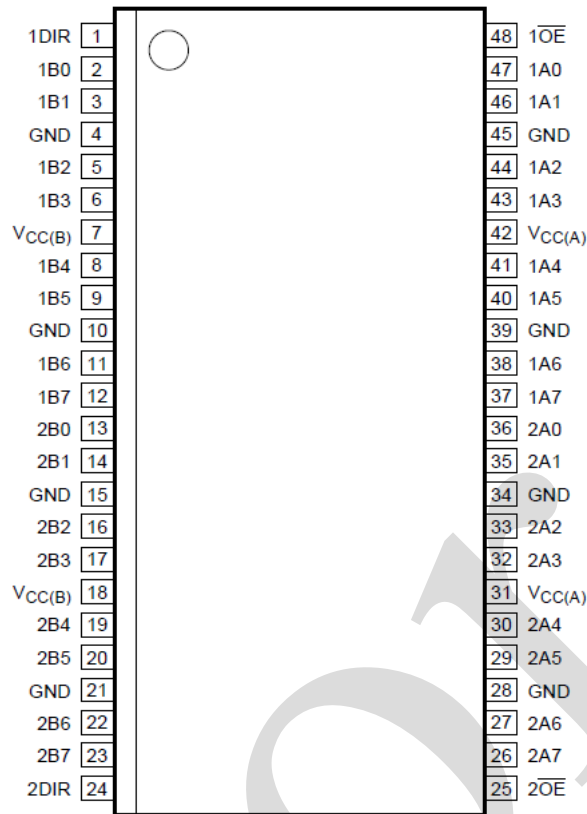

Figure 2. IEC logic symbol



2.2、Pin Configurations



2.3、Pin Description

Pin No.	Pin Name	Description
1,24	1DIR,2DIR	direction control inputs
2,3,5,6,8,9,11,12	1B0,1B1,1B2,1B3,1B4,1B5,1B6,1B7	data inputs/outputs
13,14,16,17,19,20,22,23	2B0,2B1,2B2,2B3,2B4,2B5,2B6,2B7	data inputs/outputs
4,10,15,21,28,34,39,45	GND	ground (0V)
7,18	V _{CC(B)}	supply voltage B(5V bus)
48,25	1 \overline{OE} , 2 \overline{OE}	output enable inputs(active LOW)
47,46,44,43,41,40,38,37	1A0,1A1,1A2,1A3,1A4,1A5,1A6,1A7	data inputs/outputs
36,35,33,32,30,29,27,26	2A0,2A1,2A2,2A3,2A4,2A5,2A6,2A7	data inputs/outputs
31,42	V _{CC(A)}	supply voltage A(3V bus)

2.4、Function Table

Control		Input/output	
\overline{nOE}	nDIR	nAn	nBn
L	L	nAn=nBn	inputs
L	H	inputs	nBn=nAn
H	X	Z	Z

Note: H=HIGH voltage level; L=LOW voltage level; X=don't care; Z=high-impedance OFF-state.



3、Electrical Parameter

3.1、Absolute Maximum Ratings

(Voltages are referenced to GND(ground=0V), unless otherwise specified.)

Parameter	Symbol	Conditions	Min.	Max.	Unit
supply voltage B	$V_{CC(B)}$	$V_{CC(B)} \geq V_{CC(A)}$	-0.5	+6.0	V
supply voltage A	$V_{CC(A)}$	$V_{CC(B)} \geq V_{CC(A)}$	-0.5	+4.6	V
input clamping current	I_{IK}	$V_I < 0V$	-50	-	mA
input voltage	V_I	_[1]	-0.5	+6.0	V
Input/output voltage	$V_{I/O}$	-	-0.5	$V_{CC}+0.5$	V
output clamping current	I_{OK}	$V_O > V_{CC}$ or $V_O < 0V$	-	± 50	mA
output voltage	V_O	output HIGH or LOW [1]	-0.5	$V_{CC}+0.5$	V
		output 3-state [1]	-0.5	+6.0	V
output current	$I_{O(sink/source)}$	$V_O = 0V$ to V_{CC}	-	± 50	mA
supply current	I_{CC}	-	-	100	mA
ground current	I_{GND}	-	-100	-	mA
storage temperature	T_{stg}	-	-65	+150	°C
junction temperature	T_j	_[2]	-	+150	°C
total power dissipation	P_{tot}	-	-	500	mW
Soldering temperature	T_L	10s	260		°C

Note:

[1] The input and output negative voltage ratings may be exceeded if the input and output clamp current ratings are observed.

[2] The performance capability of a high-performance integrated circuit in conjunction with its thermal environment can create junction temperatures which are detrimental to reliability.

3.2、Recommended Operating Conditions

Parameter	Symbol	Conditions	Min.	Typ.	Max.	Unit	
supply voltage B	$V_{CC(B)}$	$V_{CC(B)} \geq V_{CC(A)}$	maximum speed performance	2.7	-	5.5	V
			low-voltage applications	1.2	-	5.5	V
supply voltage A	$V_{CC(A)}$	$V_{CC(B)} \geq V_{CC(A)}$	maximum speed performance	2.7	-	3.6	V
			low-voltage applications	1.5	-	3.6	V
input voltage	V_I	control inputs: nOE and nDIR	0	-	5.5	V	
Input/output voltage	$V_{I/O}$	nAn port	0	-	$V_{CC(A)}$	V	
		nBn port	0	-	$V_{CC(B)}$	V	
output voltage	V_O	nAn port	0	-	$V_{CC(A)}$	V	
		nBn port	0	-	$V_{CC(B)}$	V	
ambient temperature	T_{amb}	-	-40	-	+125	°C	
input transition rise and fall rate	$\Delta t/\Delta V$	$V_{CC(A)} = 2.7V$ to $3.0V$	0	-	20	ns/V	
		$V_{CC(A)} = 3.0V$ to $3.6V$	0	-	10	ns/V	
		$V_{CC(B)} = 3.0V$ to $4.5V$	0	-	20	ns/V	
		$V_{CC(B)} = 4.5V$ to $5.5V$	0	-	10	ns/V	



3.3、Electrical Characteristics

3.3.1、DC Characteristics 1

($T_{amb}=-40^{\circ}\text{C}$ to $+85^{\circ}\text{C}$, voltages are referenced to GND (ground=0V), unless otherwise specified.)

Parameter	Symbol	Conditions	Min.	Typ. ^[1]	Max.	Unit	
HIGH-level input voltage	V_{IH}	nBn port $V_{CC(B)}=3.0\text{V}$ to $5.5\text{V}^{[2]}$	2.0	-	-	V	
		nAn port, n OE and nDIR $V_{CC(A)}=3.0\text{V}$ to 3.6V	2.0	-	-	V	
		$V_{CC(A)}=2.3\text{V}$ to $2.7\text{V}^{[2]}$	1.7	-	-	V	
LOW-level input voltage	V_{IL}	nBn port $V_{CC(B)}=4.5\text{V}$ to $5.5\text{V}^{[2]}$	-	-	0.8	V	
		$V_{CC(B)}=3.0\text{V}$ to $3.6\text{V}^{[2]}$	-	-	0.7	V	
		nAn port, n OE and nDIR $V_{CC(A)}=3.0\text{V}$ to 3.6V	-	-	0.8	V	
		$V_{CC(A)}=2.3\text{V}$ to $2.7\text{V}^{[2]}$	-	-	0.7	V	
HIGH-level output voltage	V_{OH}	nBn port; $V_I=V_{IH}$ or V_{IL}	$I_O=-24\text{mA}$; $V_{CC(B)}=4.5\text{V}$	$V_{CC(B)}-0.8$	-	-	V
			$I_O=-12\text{mA}$; $V_{CC(B)}=4.5\text{V}$	$V_{CC(B)}-0.5$	-	-	V
			$I_O=-18\text{mA}$; $V_{CC(B)}=3.0\text{V}$	$V_{CC(B)}-0.8$	-	-	V
			$I_O=-100\mu\text{A}$; $V_{CC(B)}=3.0\text{V}$	$V_{CC(B)}-0.2$	$V_{CC(B)}$	-	V
	nAn port; $V_I=V_{IH}$ or V_{IL}	$I_O=-24\text{mA}$; $V_{CC(A)}=3.0\text{V}$	$V_{CC(A)}-0.7$	-	-	V	
		$I_O=-100\mu\text{A}$; $V_{CC(A)}=3.0\text{V}$	$V_{CC(A)}-0.2$	-	-	V	
		$I_O=-12\text{mA}$; $V_{CC(A)}=2.7\text{V}$	$V_{CC(A)}-0.5$	-	-	V	
		$I_O=-8\text{mA}$; $V_{CC(A)}=2.3\text{V}$	$V_{CC(A)}-0.6$	-	-	V	
		$I_O=-100\mu\text{A}$; $V_{CC(A)}=2.3\text{V}$	$V_{CC(A)}-0.2$	$V_{CC(A)}$	-	V	
LOW-level output voltage	V_{OL}	nBn port; $V_I=V_{IH}$ or V_{IL}	$I_O=24\text{mA}$; $V_{CC(B)}=4.5\text{V}$	-	-	0.55	V
			$I_O=12\text{mA}$; $V_{CC(B)}=4.5\text{V}$	-	-	0.40	V
			$I_O=100\mu\text{A}$; $V_{CC(B)}=4.5\text{V}$	-	-	0.20	V
			$I_O=18\text{mA}$; $V_{CC(B)}=3.0\text{V}$	-	-	0.55	V
			$I_O=100\mu\text{A}$; $V_{CC(B)}=3.0\text{V}$	-	-	0.20	V
		nAn port; $V_I=V_{IH}$ or V_{IL}	$I_O=24\text{mA}$; $V_{CC(A)}=3.0\text{V}$	-	-	0.55	V
			$I_O=100\mu\text{A}$; $V_{CC(A)}=3.0\text{V}$	-	-	0.20	V
			$I_O=12\text{mA}$; $V_{CC(A)}=2.7\text{V}$	-	-	0.40	V
			$I_O=12\text{mA}$; $V_{CC(A)}=2.3\text{V}$	-	-	0.60	V
			$I_O=100\mu\text{A}$; $V_{CC(A)}=2.3\text{V}$	-	-	0.20	V
input leakage current	I_I	$V_I=5.5\text{V}$ or GND	-	-	± 5	μA	
OFF-state output current	I_{OZ}	$V_I=V_{IH}$ or V_{IL} ; $V_O=V_{CC}$ or GND ^[3]	-	-	± 10	μA	
supply current	I_{CC}	$V_I=V_{CC}$ or GND; $I_O=0\text{A}$	-	-	40	μA	
additional supply current	ΔI_{CC}	per control pin; $V_I=V_{CC}-0.6\text{V}$; $I_O=0\text{A}$ ^[4]	-	-	500	μA	
input capacitance	C_I	-	-	4.0	-	pF	
input/output capacitance	$C_{I/O}$	nAn and nBn port	-	5.0	-	pF	

Note:

[1] All typical values are measured at $V_{CC(B)}=5.0\text{V}$, $V_{CC(A)}=3.3\text{V}$ and $T_{amb}=25^{\circ}\text{C}$.



[2] If $V_{CC(A)} < 2.7V$, the switching levels at all inputs are not TTL compatible.

[3] For transceivers, the parameter I_{OZ} includes the input leakage current.

[4] $V_{CC(A)} = 2.7V$ to $3.6V$: other inputs at $V_{CC(A)}$ or GND; $V_{CC(B)} = 4.5V$ to $5.5V$: other inputs at $V_{CC(B)}$ or GND.

3.3.2、DC Characteristics 2

($T_{amb} = -40^{\circ}C$ to $+125^{\circ}C$, voltages are referenced to GND (ground=0V), unless otherwise specified.)

Parameter	Symbol	Conditions	Min.	Typ. ^[1]	Max.	Unit	
HIGH-level input voltage	V_{IH}	nBn port	$V_{CC(B)} = 3.0V$ to $5.5V$ ^[2]	2.0	-	-	V
		nAn port, n OE and nDIR	$V_{CC(A)} = 3.0V$ to $3.6V$	2.0	-	-	V
			$V_{CC(A)} = 2.3V$ to $2.7V$ ^[2]	1.7	-	-	V
LOW-level input voltage	V_{IL}	nBn port	$V_{CC(B)} = 4.5V$ to $5.5V$ ^[2]	-	-	0.8	V
			$V_{CC(B)} = 3.0V$ to $3.6V$ ^[2]	-	-	0.7	V
		nAn port, n OE and nDIR	$V_{CC(A)} = 3.0V$ to $3.6V$	-	-	0.8	V
			$V_{CC(A)} = 2.3V$ to $2.7V$ ^[2]	-	-	0.7	V
HIGH-level output voltage	V_{OH}	nBn port; $V_I = V_{IH}$ or V_{IL}	$I_O = -24mA$; $V_{CC(B)} = 4.5V$	$V_{CC(B)} - 1.2$	-	-	V
			$I_O = -12mA$; $V_{CC(B)} = 4.5V$	$V_{CC(B)} - 0.8$	-	-	V
			$I_O = -18mA$; $V_{CC(B)} = 3.0V$	$V_{CC(B)} - 1.0$	-	-	V
			$I_O = -100\mu A$; $V_{CC(B)} = 3.0V$	$V_{CC(B)} - 0.3$	-	-	V
		nAn port; $V_I = V_{IH}$ or V_{IL}	$I_O = -24mA$; $V_{CC(A)} = 3.0V$	$V_{CC(A)} - 1.0$	-	-	V
			$I_O = -100\mu A$; $V_{CC(A)} = 3.0V$	$V_{CC(A)} - 0.3$	-	-	V
			$I_O = -12mA$; $V_{CC(A)} = 2.7V$	$V_{CC(A)} - 0.8$	-	-	V
			$I_O = -8mA$; $V_{CC(A)} = 2.3V$	$V_{CC(A)} - 0.6$	-	-	V
			$I_O = -100\mu A$; $V_{CC(A)} = 2.3V$	$V_{CC(A)} - 0.3$	-	-	V
LOW-level output voltage	V_{OL}	nBn port; $V_I = V_{IH}$ or V_{IL}	$I_O = 24mA$; $V_{CC(B)} = 4.5V$	-	-	0.60	V
			$I_O = 12mA$; $V_{CC(B)} = 4.5V$	-	-	0.80	V
			$I_O = 100\mu A$; $V_{CC(B)} = 4.5V$	-	-	0.30	V
			$I_O = 18mA$; $V_{CC(B)} = 3.0V$	-	-	0.80	V
			$I_O = 100\mu A$; $V_{CC(B)} = 3.0V$	-	-	0.30	V
		nAn port; $V_I = V_{IH}$ or V_{IL}	$I_O = 24mA$; $V_{CC(A)} = 3.0V$	-	-	0.80	V
			$I_O = 100\mu A$; $V_{CC(A)} = 3.0V$	-	-	0.30	V
			$I_O = 12mA$; $V_{CC(A)} = 2.7V$	-	-	0.60	V
			$I_O = 12mA$; $V_{CC(A)} = 2.3V$	-	-	0.60	V
			$I_O = 100\mu A$; $V_{CC(A)} = 2.3V$	-	-	0.20	V
input leakage current	I_I	$V_I = 5.5V$ or GND	-	-	± 10	μA	
OFF-state output current	I_{OZ}	$V_I = V_{IH}$ or V_{IL} ; $V_O = V_{CC}$ or GND ^[3]	-	-	± 20	μA	
supply current	I_{CC}	$V_I = V_{CC}$ or GND; $I_O = 0A$	-	-	80	μA	
additional supply current	ΔI_{CC}	per control pin; $V_I = V_{CC} - 0.6V$; $I_O = 0A$ ^[4]	-	-	5000	μA	

Note:

[1] All typical values are measured at $V_{CC(B)} = 5.0V$, $V_{CC(A)} = 3.3V$ and $T_{amb} = 25^{\circ}C$.



[2] If $V_{CC(A)} < 2.7V$, the switching levels at all inputs are not TTL compatible.

[3] For transceivers, the parameter I_{OZ} includes the input leakage current.

[4] $V_{CC(A)} = 2.7V$ to $3.6V$: other inputs at $V_{CC(A)}$ or GND; $V_{CC(B)} = 4.5V$ to $5.5V$: other inputs at $V_{CC(B)}$ or GND.

3.3.3、AC Characteristics 1

($T_{amb} = -40^{\circ}C$ to $+85^{\circ}C$, GND=0V; $t_r = t_f \leq 2.5ns$; $C_L = 50pF$; voltages are referenced to GND (ground=0V), unless otherwise specified.)

Parameter	Symbol	Conditions	Min.	Typ. ^[1]	Max.	Unit	
propagation delay	t_{pd}	nAn to nBn; see Figure 4 ^[2]	$V_{CC(A)} = 2.3V$ to $2.7V$; $V_{CC(B)} = 3.0V$ to $3.6V$	1.5	3.3	7.6	ns
			$V_{CC(A)} = 2.7V$; $V_{CC(B)} = 4.5V$ to $5.5V$	1.0	3.0	5.9	ns
			$V_{CC(A)} = 3.0V$ to $3.6V$; $V_{CC(B)} = 4.5V$ to $5.5V$	1.0	2.9	5.8	ns
		nBn to nAn; see Figure 4 ^[2]	$V_{CC(A)} = 2.3V$ to $2.7V$; $V_{CC(B)} = 3.0V$ to $3.6V$	1.0	3.0	7.6	ns
			$V_{CC(A)} = 2.7V$; $V_{CC(B)} = 4.5V$ to $5.5V$	1.0	4.3	6.7	ns
			$V_{CC(A)} = 3.0V$ to $3.6V$; $V_{CC(B)} = 4.5V$ to $5.5V$	1.2	2.5	5.8	ns
enable time	t_{en}	n OE to nBn; see Figure 5 ^[3]	$V_{CC(A)} = 2.3V$ to $2.7V$; $V_{CC(B)} = 3.0V$ to $3.6V$	1.5	4.1	11.5	ns
			$V_{CC(A)} = 2.7V$; $V_{CC(B)} = 4.5V$ to $5.5V$	1.5	3.6	9.2	ns
			$V_{CC(A)} = 3.0V$ to $3.6V$; $V_{CC(B)} = 4.5V$ to $5.5V$	1.0	3.2	8.9	ns
		n OE to nAn; see Figure 5 ^[3]	$V_{CC(A)} = 2.3V$ to $2.7V$; $V_{CC(B)} = 3.0V$ to $3.6V$	1.5	4.6	12.3	ns
			$V_{CC(A)} = 2.7V$; $V_{CC(B)} = 4.5V$ to $5.5V$	1.5	4.3	9.3	ns
			$V_{CC(A)} = 3.0V$ to $3.6V$; $V_{CC(B)} = 4.5V$ to $5.5V$	1.0	3.2	8.9	ns
disable time	t_{dis}	n OE to nBn; see Figure 5 ^[4]	$V_{CC(A)} = 2.3V$ to $2.7V$; $V_{CC(B)} = 3.0V$ to $3.6V$	2.0	2.7	10.5	ns
			$V_{CC(A)} = 2.7V$; $V_{CC(B)} = 4.5V$ to $5.5V$	2.5	4.6	9.0	ns
			$V_{CC(A)} = 3.0V$ to $3.6V$; $V_{CC(B)} = 4.5V$ to $5.5V$	2.1	4.9	8.6	ns
		n OE to nAn; see Figure 5 ^[4]	$V_{CC(A)} = 2.3V$ to $2.7V$; $V_{CC(B)} = 3.0V$ to $3.6V$	1.0	2.7	9.3	ns
			$V_{CC(A)} = 2.7V$; $V_{CC(B)} = 4.5V$ to $5.5V$	1.5	3.5	9.0	ns
			$V_{CC(A)} = 3.0V$ to $3.6V$; $V_{CC(B)} = 4.5V$ to $5.5V$	2.0	3.2	8.6	ns
power dissipation	C_{PD}	5V port:nAn to nBn; $V_I = GND$ to V_{CC} ;	outputs enabled	-	30	-	pF



capacitance		$V_{CC(B)}=5V$; $V_{CC(A)}=3.3V^{[5]}$	outputs disabled	-	15	-	pF
	3V port:nBn to nAn; $V_I=GND$ to V_{CC} ;	$V_{CC(B)}=5V$; $V_{CC(A)}=3.3V^{[5]}$	outputs enabled	-	40	-	pF
			outputs disabled	-	5	-	pF

Note:

[1] All typical values are measured at nominal voltage for $V_{CC(B)}$ and $V_{CC(A)}$ and at $T_{amb}=25^{\circ}C$.[2] t_{pd} is the same as t_{PLH} and t_{PHL} .[3] t_{en} is the same as t_{PZL} and t_{PZH} .[4] t_{dis} is the same as t_{PLZ} and t_{PHZ} .[5] C_{PD} is used to determine the dynamic power dissipation (P_D in uW). $P_D=C_{PD} \times V_{CC}^2 \times f_i \times N + \Sigma(C_L \times V_{CC}^2 \times f_o)$ where: f_i =input frequency in MHz; f_o =output frequency in MHz; C_L =output load capacitance in pF; V_{CC} =supply voltage in V; N =number of inputs switching; $\Sigma(C_L \times V_{CC}^2 \times f_o)$ =sum of outputs.

3.3.4. AC Characteristics 2

 $(T_{amb}=-40^{\circ}C$ to $+125^{\circ}C$, $GND=0V$; $t_r=t_f \leq 2.5ns$; $C_L=50pF$; voltages are referenced to GND (ground=0V), unless otherwise specified.)

Parameter	Symbol	Conditions	Min.	Typ. ^[1]	Max.	Unit	
propagation delay	t_{pd}	nAn to nBn; see Figure 4 ^[2]	$V_{CC(A)}=2.3V$ to $2.7V$; $V_{CC(B)}=3.0V$ to $3.6V$	1.5	-	9.5	ns
			$V_{CC(A)}=2.7V$; $V_{CC(B)}=4.5V$ to $5.5V$	1.0	-	7.5	ns
			$V_{CC(A)}=3.0V$ to $3.6V$; $V_{CC(B)}=4.5V$ to $5.5V$	1.0	-	7.5	ns
		nBn to nAn; see Figure 4 ^[2]	$V_{CC(A)}=2.3V$ to $2.7V$; $V_{CC(B)}=3.0V$ to $3.6V$	1.0	-	9.5	ns
			$V_{CC(A)}=2.7V$; $V_{CC(B)}=4.5V$ to $5.5V$	1.0	-	8.5	ns
			$V_{CC(A)}=3.0V$ to $3.6V$; $V_{CC(B)}=4.5V$ to $5.5V$	1.2	-	7.5	ns
enable time	t_{en}	n OE to nBn; see Figure 5 ^[3]	$V_{CC(A)}=2.3V$ to $2.7V$; $V_{CC(B)}=3.0V$ to $3.6V$	1.5	-	14.5	ns
			$V_{CC(A)}=2.7V$; $V_{CC(B)}=4.5V$ to $5.5V$	1.5	-	11.5	ns
			$V_{CC(A)}=3.0V$ to $3.6V$; $V_{CC(B)}=4.5V$ to $5.5V$	1.0	-	12.0	ns
		n OE to nAn; see Figure 5 ^[3]	$V_{CC(A)}=2.3V$ to $2.7V$; $V_{CC(B)}=3.0V$ to $3.6V$	1.5	-	15.5	ns
			$V_{CC(A)}=2.7V$; $V_{CC(B)}=4.5V$ to $5.5V$	1.5	-	12.0	ns



			$V_{CC(A)}=3.0V$ to $3.6V$; $V_{CC(B)}=4.5V$ to $5.5V$	1.0	-	11.5	ns
disable time	t_{dis}	n OE to nBn; see Figure 5 ^[4]	$V_{CC(A)}=2.3V$ to $2.7V$; $V_{CC(B)}=3.0V$ to $3.6V$	2.0	-	13.5	ns
			$V_{CC(A)}=2.7V$; $V_{CC(B)}=4.5V$ to $5.5V$	2.5	-	11.5	ns
			$V_{CC(A)}=3.0V$ to $3.6V$; $V_{CC(B)}=4.5V$ to $5.5V$	2.1	-	11.0	ns
		n OE to nAn; see Figure 5 ^[4]	$V_{CC(A)}=2.3V$ to $2.7V$; $V_{CC(B)}=3.0V$ to $3.6V$	1.0	-	12.0	ns
			$V_{CC(A)}=2.7V$; $V_{CC(B)}=4.5V$ to $5.5V$	1.5	-	11.5	ns
			$V_{CC(A)}=3.0V$ to $3.6V$; $V_{CC(B)}=4.5V$ to $5.5V$	2.0	-	11.0	ns

Note:

[1] All typical values are measured at nominal voltage for $V_{CC(B)}$ and $V_{CC(A)}$ and at $T_{amb}=25^{\circ}C$.

[2] t_{pd} is the same as t_{PLH} and t_{PHL} .

[3] t_{en} is the same as t_{PZL} and t_{PZH} .

[4] t_{dis} is the same as t_{PLZ} and t_{PHZ} .

4、Testing Circuit

4.1、AC Testing Circuit

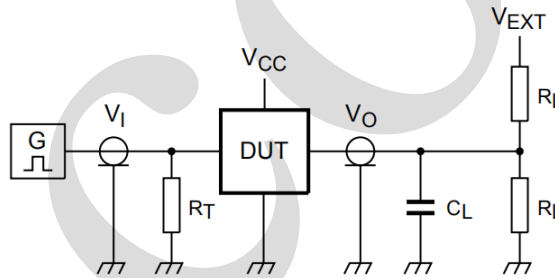

Definitions test circuit:

R_L =Load resistance.

C_L =Load capacitance including jig and probe capacitance.

R_T =Termination resistance should be equal to output impedance Z_o of the pulse generator.

Figure 3. Test circuit for measuring switching times

4.2、Test Data

Direction	Supply voltage		Load		V_{EXT}		
	$V_{CC(A)}$	$V_{CC(B)}$	C_L	R_L	t_{PLH}, t_{PHL}	t_{PZH}, t_{PHZ}	t_{PZL}, t_{PLZ}
nAn port to nBn port	2.3V to 2.7V	2.7V to 3.6V	50pF	500Ω	open	GND	$2 \times V_{CC}$
nBn port to nAn port	2.3V to 2.7V	2.7V to 3.6V	50pF	500Ω	open	GND	6.0V
nAn port to nBn port	2.7V to 3.6V	4.5V to 5.5V	50pF	500Ω	open	GND	$2 \times V_{CC}$
nBn port to nAn port	2.7V to 3.6V	4.5V to 5.5V	50pF	500Ω	open	GND	6.0V



4.3、 AC Testing Waveforms

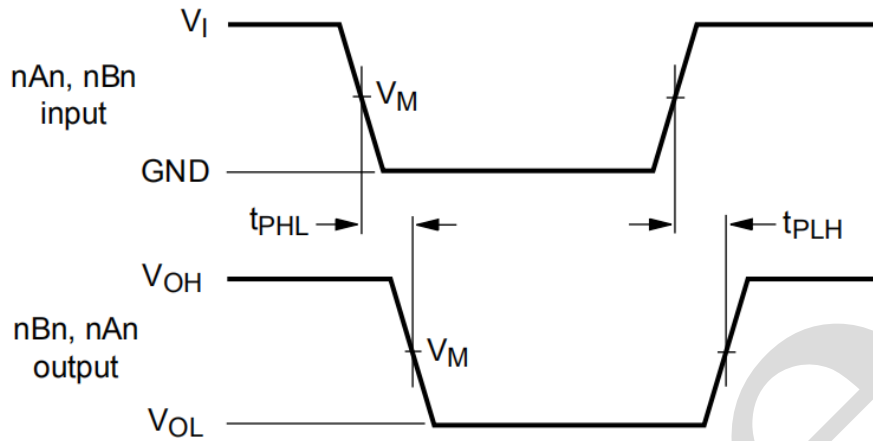

V_{OL} and V_{OH} are typical voltage output levels that occur with the output load.

Figure 4. Input (nAn,nBn) to output (nBn,nAn) propagation delays

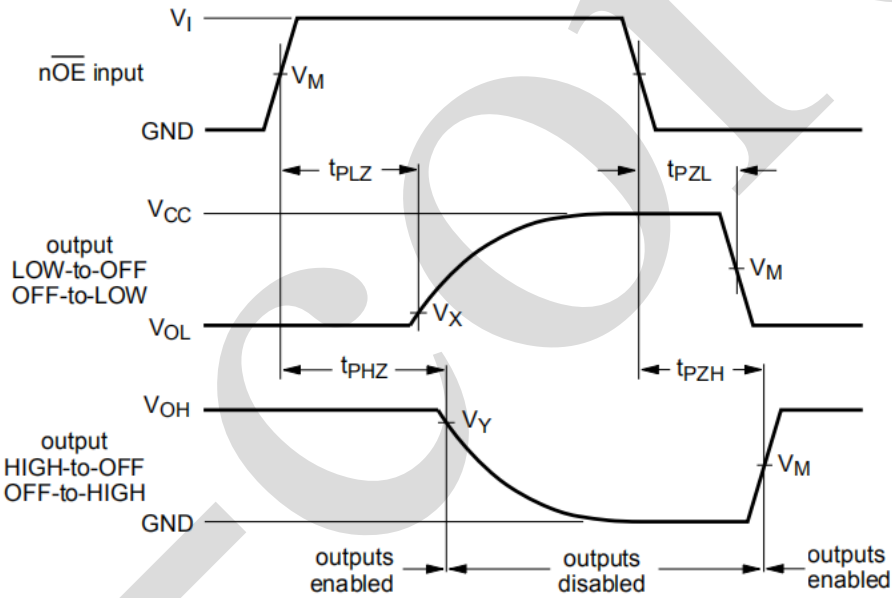

V_{OL} and V_{OH} are typical voltage output levels that occur with the output load.

Figure 5. 3-state enable and disable times

4.4、 Measurement points

Direction	Supply voltage		Input		Output		
	$V_{CC(A)}$	$V_{CC(B)}$	V_I	V_M	V_M	V_X	V_Y
nAn port to nBn port	2.3V to 2.7V	2.7V to 3.6V	$V_{CC(A)}$	$0.5 \times V_{CC(A)}$	1.5V	$V_{OL(B)}+0.3V$	$V_{OH(B)}-0.3V$
nBn port to nAn port	2.3V to 2.7V	2.7V to 3.6V	2.7V	1.5V	$0.5 \times V_{CC(A)}$	$V_{OL(A)}+0.15V$	$V_{OH(A)}-0.15V$
nAn port to nBn port	2.7V to 3.6V	4.5V to 5.5V	2.7V	1.5V	$0.5 \times V_{CC(B)}$	$0.2 \times V_{CC(B)}$	$0.8 \times V_{CC(B)}$
nBn port to nAn port	2.7V to 3.6V	4.5V to 5.5V	3.0V	1.5V	1.5V	$V_{OL(A)}+0.3V$	$V_{OH(A)}-0.3V$



5、Package Information

5.1、TSSOP48

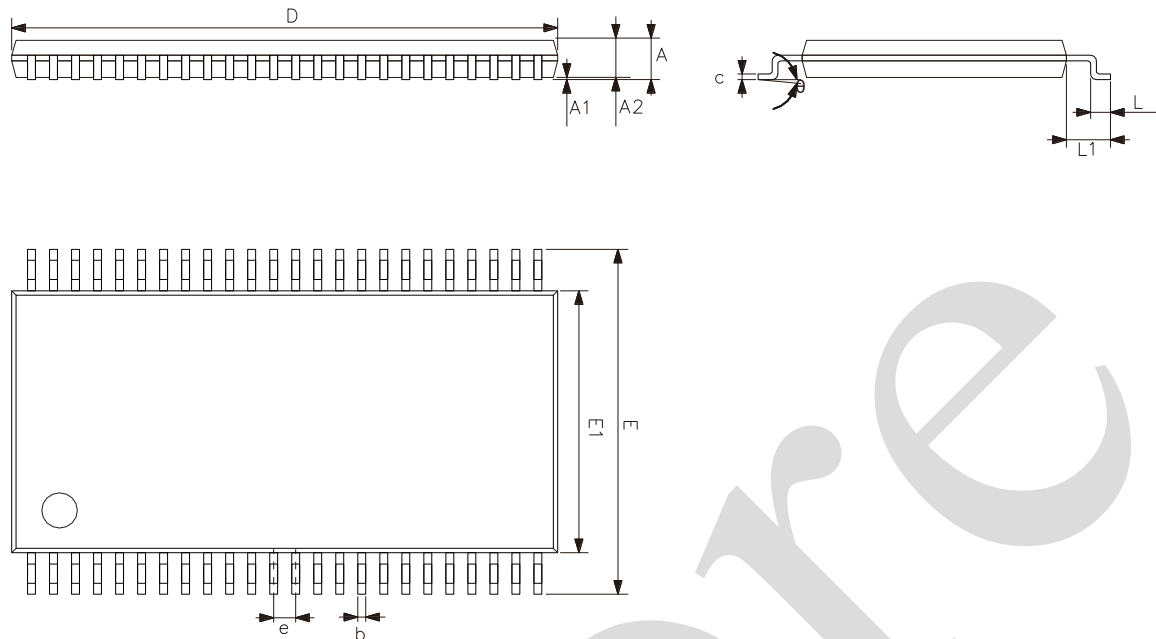

Symbol	Dimensions (mm)	
	Min.	Max.
A	-	1.20
A1	0.03	0.15
A2	0.82	1.05
b	0.17	0.27
c	0.12	0.22
D	12.40	12.60
E	7.90	8.30
E1	6.00	6.20
e	0.50	
L	0.35	0.75
L1	1.00	
θ	0°	8°



5.2、SSOP48

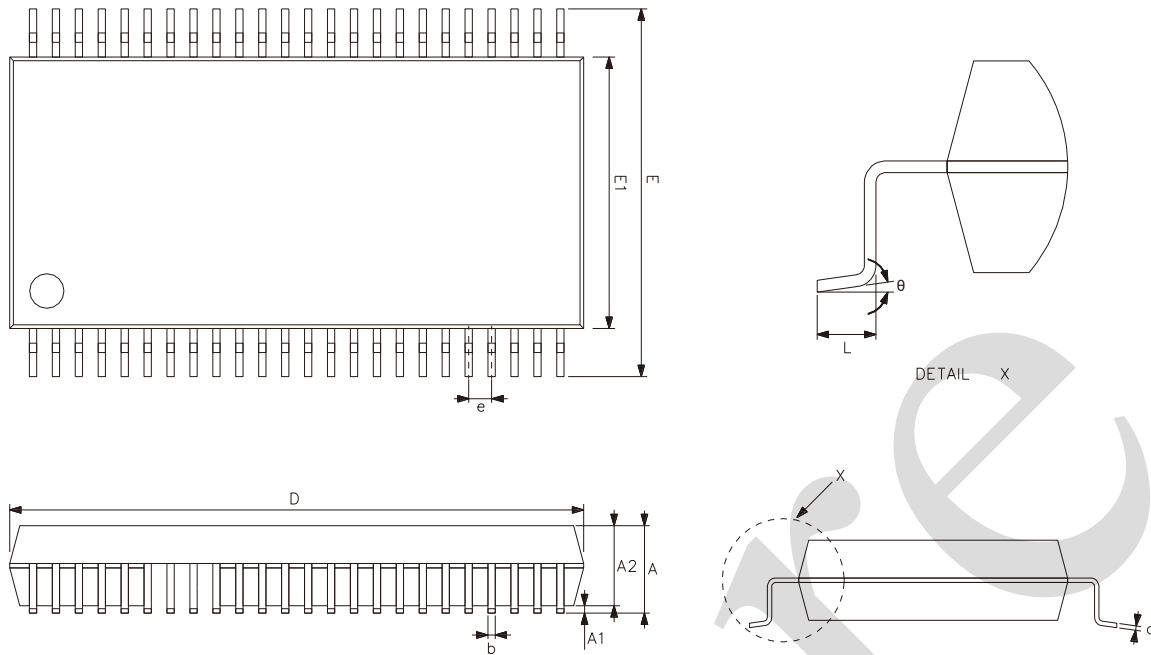

Symbol	Dimensions (mm)	
	Min.	Max.
A	-	2.85
A1	0.15	0.45
A2	2.10	2.45
b	0.20	0.35
c	0.12	0.25
D	15.60	16.05
E	9.80	10.80
E1	7.35	7.65
e	0.635	
L	0.56	0.95
θ	0°	8°



6、 Statements And Notes

6.1、 The name and content of Hazardous substances or Elements in the product

Part name	Hazardous substances or Elements									
	Lead and lead compounds	Mercury and mercury compounds	Cadmium and cadmium compounds	Hexavalent chromium compounds	Polybrominated biphenyls	Polybrominated biphenyl ethers	Dibutyl phthalate	Butylbenzyl phthalate	Di-2-ethylhexyl phthalate	Diisobutyl phthalate
Lead frame	○	○	○	○	○	○	○	○	○	○
Plastic resin	○	○	○	○	○	○	○	○	○	○
Chip	○	○	○	○	○	○	○	○	○	○
The lead	○	○	○	○	○	○	○	○	○	○
Plastic sheet installed	○	○	○	○	○	○	○	○	○	○
explanation	○: Indicates that the content of hazardous substances or elements in the detection limit of the following the SJ/T11363-2006 standard. ×: Indicates that the content of hazardous substances or elements exceeding the SJ/T11363-2006 Standard limit requirements.									

6.2、 Notes

We Recommend you to read this chapter carefully before using this product.

The information in this chapter is provided for reference only and i-Core disclaims any express or implied warranties, including but not limited to applicability, special application or non-infringement of third party rights.

This product is not suitable for critical equipment such as life-saving, life-sustaining or safety equipment. It is also not suitable for applications that may result in personal injury, death, or serious property or environmental damage due to product malfunction or failure. I-Core will not be liable for any damages incurred by the customers at their own risk for such applications.

The customer is responsible for conducting all necessary tests i-Core's application to avoid failure in the application or the application of the customer's third party users. I-Core does not accept any liability.

The Company reserves the right to change or improve the information published in this chapter at any time. The information in this chapter are subject to change without notice. We recommend the customer to consult our sales staff before purchasing.

Please obtain related materials form i-Core's regular channels and we are not responsible for its content if it is provided by sources other than our company.

In case of any conflict between the Chinese and English version, the version is subject to the Chinese one.