



AiP74LVC4245

Octal dual supply translating transceiver; 3-state

Product Specification

Specification Revision History:

Version	Date	Description
2017-04-A1	2017-04	New
2023-04-B1	2023-04	Update the template
2023-11-B2	2023-11	Modify ordering information



Contents

1、 General Description.....	3
2、 Block Diagram And Pin Description	5
2.1、 Block Diagram	5
2.2、 Pin Configurations.....	6
2.3、 Pin Description	6
2.4、 Function Table.....	7
3、 Electrical Parameter	7
3.1、 Absolute Maximum Ratings.....	7
3.2、 Recommended Operating Conditions	8
3.3、 Electrical Characteristics	8
3.3.1、 DC Characteristics 1	8
3.3.2、 DC Characteristics 2	10
3.3.3、 AC Characteristics 1	11
3.3.4、 AC Characteristics 2	12
4、 Testing Circuit	13
4.1、 AC Testing Circuit	13
4.2、 Test Data	13
4.3、 AC Testing Waveforms.....	14
5、 Package Information	16
5.1、 SOP24	16
5.2、 SSOP24	17
5.3、 TSSOP24.....	18
5.4、 DHVQFN24	19
6、 Statements And Notes	20
6.1、 The name and content of Hazardous substances or Elements in the product	20
6.2、 Notes	20



1、 General Description

The AiP74LVC4245 is an octal dual supply translating transceiver featuring non-inverting 3-state bus compatible outputs in both send and receive directions. It is designed to interface between a 3V and 5V bus in a mixed 3V and 5V supply environment.

The device features an output enable input (pin \overline{OE}) for easy cascading and a send/receive input (pin DIR) for direction control. Pin \overline{OE} controls the outputs so that the buses are effectively isolated.

In suspend mode, when $V_{CC(A)}$ is zero, there will be no current flow from one supply to the other supply. The A-outputs must be set 3-state and the voltage on the A-bus must be smaller than V_{diode} (typical 0.7V).

$V_{CC(A)} \geq V_{CC(B)}$, except in suspend mode.

Features:

- 5V tolerant inputs/outputs, for interfacing with 5V logic
- Wide supply voltage range:
 - 3V bus ($V_{CC(B)}$): 1.5V to 3.6V
 - 5V bus ($V_{CC(A)}$): 1.5V to 5.5V
- CMOS low-power consumption
- Direct interface with TTL levels
- Inputs accept voltages up to 5.5V
- High-impedance when $V_{CC(A)}=0V$
- Specified from $-40^{\circ}C$ to $+125^{\circ}C$
- Packaging information:SOP24/SSOP24/TSSOP24/DHVQFN24

**Ordering Information:****Tube packing specifications:**

Part number	Packaging form	Marking code	Tube quantity	Boxed tube quantity	Boxed quantity	Notes
AiP74LVC4245 SA24.TB	SOP24	74LVC4245	30 PCS/tube	80 tube/box	2400 PCS/box	Dimensions of plastic enclosure: 15.4mm×7.5mm Pin spacing: 1.27mm
AiP74LVC4245 VB24.TB	SSOP24	74LVC4245	50 PCS/tube	200 tube/box	10000 PCS/box	Dimensions of plastic enclosure: 8.7mm×3.9mm Pin spacing: 0.635mm
AiP74LVC4245 TA24.TB	TSSOP24	74LVC4245	62 PCS/tube	200 tube/box	12400 PCS/box	Dimensions of plastic enclosure: 7.8mm×4.4mm Pin spacing: 0.65mm

Reel packing specifications:

Part number	Packaging form	Marking code	Reel quantity	Boxed reel quantity	Notes
AiP74LVC4245 SA24.TR	SOP24	74LVC4245	1250PCS/reel	1250PCS/box	Dimensions of plastic enclosure: 15.4mm×7.5mm Pin spacing: 1.27mm
AiP74LVC4245 VB24.TR	SSOP24	74LVC4245	4000PCS/reel	8000PCS/box	Dimensions of plastic enclosure: 8.7mm×3.9mm Pin spacing: 0.635mm
AiP74LVC4245 TA24.TR	TSSOP24	74LVC4245	4000PCS/reel	8000PCS/box	Dimensions of plastic enclosure: 7.8mm×4.4mm Pin spacing: 0.65mm
AiP74LVC4245 QE24.TR	DHVQFN24	74LVC4245	3000PCS/reel	3000PCS/box	Dimensions of plastic enclosure: 5.5mm×3.5mm Pin spacing: 0.5mm

Note: If the physical information is inconsistent with the ordering information, please refer to the actual product.



2、Block Diagram And Pin Description

2.1、Block Diagram

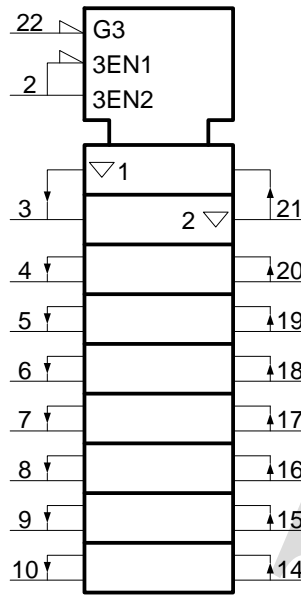

Figure 1. IEC Logic symbol

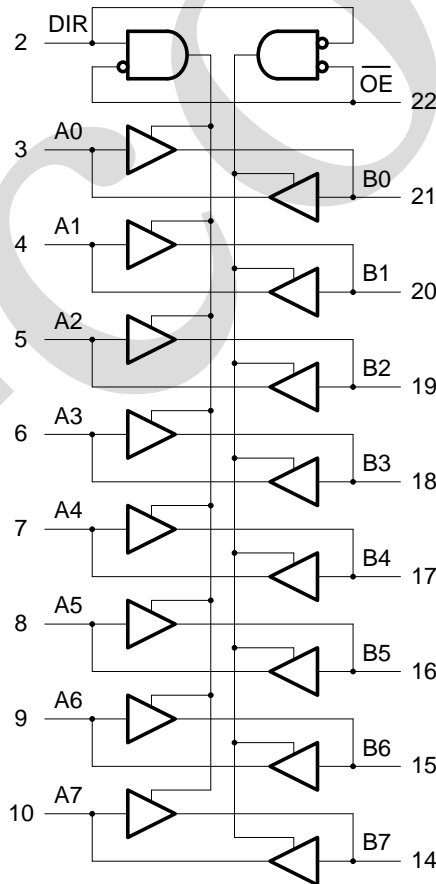
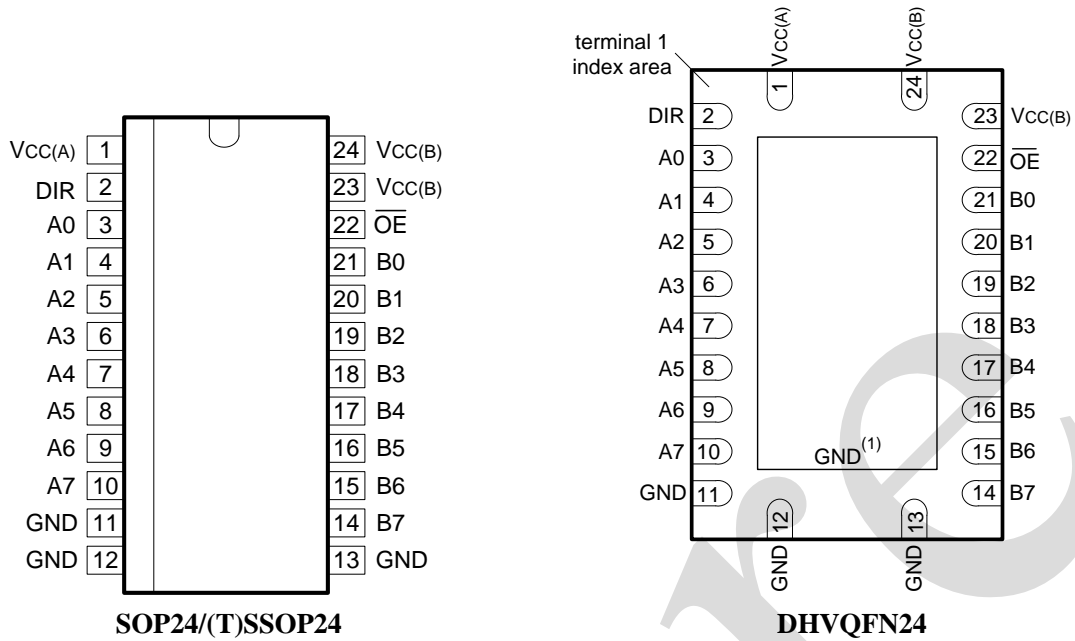

Figure 2. Logic diagram



2.2、Pin Configurations



Note:

- (1) This is not a supply pin. The substrate is attached to this pad using conductive die attach material. There is no electrical or mechanical requirement to solder this pad. However, if it is soldered, the solder land should remain floating or be connected to GND.

2.3、Pin Description

Pin No.	Pin Name	Description
1	V _{CC(A)}	supply voltage (5V bus)
2	DIR	direction control
3	A0	data input or output
4	A1	data input or output
5	A2	data input or output
6	A3	data input or output
7	A4	data input or output
8	A5	data input or output
9	A6	data input or output
10	A7	data input or output
11	GND	ground (0V)
12	GND	ground (0V)
13	GND	ground (0V)
14	B7	data input or output
15	B6	data input or output
16	B5	data input or output
17	B4	data input or output
18	B3	data input or output
19	B2	data input or output
20	B1	data input or output



21	B0	data input or output
22	$\overline{\text{OE}}$	output enable input (active LOW)
23	$V_{CC(B)}$	supply voltage (3V bus)
24	$V_{CC(B)}$	supply voltage (3V bus)

2.4、Function Table

Input		Input/output	
$\overline{\text{OE}}$	DIR	An	Bn
L	L	A=B	input
L	H	input	B=A
H	X	Z	Z

Note: H = HIGH voltage level; L = LOW voltage level; X = don't care; Z = high-impedance OFF-state.

3、Electrical Parameter

3.1、Absolute Maximum Ratings

(Voltages are referenced to GND (ground=0V), unless otherwise specified)

Characteristic	Symbol	Conditions	Min.	Max.	Unit
supply voltage A	$V_{CC(A)}$	-	-0.5	+6.5	V
supply voltage B	$V_{CC(B)}$	-	-0.5	+4.6	V
input clamping current	I_{IK}	$V_I < 0V$	-50	-	mA
input voltage	V_I	- ^[1]	-0.5	+6.5	V
output clamping current	I_{OK}	$V_O > V_{CCO}$ or $V_O < 0V$ ^[2]	-	± 50	mA
output voltage	V_O	output HIGH or LOW state ^[1]	-0.5	$V_{CC} + 0.5$	V
		output 3-state ^[1]	-0.5	+6.5	V
output current	I_O	$V_O = 0V$ to V_{CCO} ^[2]	-	± 50	mA
supply current	I_{CC}	-	-	100	mA
ground current	I_{GND}	-	-100	-	mA
storage temperature	T_{stg}	-	-65	+150	°C
total power dissipation	P_{tot}	-	-	500	mW
soldering temperature	T_L	10s	260		°C

Note:

[1] The input and output voltage ratings may be exceeded if the input and output current ratings are observed.

[2] V_{CCO} is the supply voltage associated with the output.



3.2、Recommended Operating Conditions

Parameter	Symbol	Conditions	Min.	Typ.	Max.	Unit
supply voltage A	$V_{CC(A)}$	$V_{CC(A)} \geq V_{CC(B)}$; see Figure 4 for maximum speed performance	1.5	-	5.5	V
supply voltage B	$V_{CC(B)}$	$V_{CC(A)} \geq V_{CC(B)}$; see Figure 4 for low-voltage applications	1.5	-	3.6	V
input voltage	V_I	for control inputs	0	-	5.5	V
output voltage	V_O	output HIGH or LOW state	0	-	V_{CC}	V
		output 3-state	0	-	5.5	V
ambient temperature	T_{amb}	-	-40	-	+125	°C
input transition rise and fall rate	$\Delta t/\Delta V$	$V_{CC(B)}=2.7V$ to $3.0V$	-	-	20	ns/V
		$V_{CC(B)}=3.0V$ to $3.6V$	-	-	10	ns/V
		$V_{CC(A)}=3.0V$ to $4.5V$	-	-	20	ns/V
		$V_{CC(A)}=4.5V$ to $5.5V$	-	-	10	ns/V

3.3、Electrical Characteristics

3.3.1、DC Characteristics 1

($T_{amb}=-40^{\circ}C$ to $+85^{\circ}C$, voltages are referenced to GND (ground=0V), unless otherwise specified)

Parameter	Symbol	Conditions	Min.	Typ. ^[1]	Max.	Unit	
HIGH-level input voltage	V_{IH}	$V_{CC(B)}=2.7V$ to $3.6V$	2.0	-	-	V	
		$V_{CC(A)}=4.5V$ to $5.5V$	2.0	-	-	V	
LOW-level input voltage	V_{IL}	$V_{CC(B)}=2.7V$ to $3.6V$	-	-	0.8	V	
		$V_{CC(A)}=4.5V$ to $5.5V$	-	-	0.8	V	
HIGH-level output voltage	V_{OH}	$V_I=V_{IH}$ or V_{IL}	$V_{CC(B)}=2.7V$ to $3.6V$; $I_O=-100\mu A$	$V_{CC(B)}-0.2$	$V_{CC(B)}$	-	V
			$V_{CC(B)}=2.7V$; $I_O=-12mA$	$V_{CC(B)}-0.5$	-	-	V
			$V_{CC(B)}=3.0V$; $I_O=-24mA$	$V_{CC(B)}-0.8$	-	-	V
			$V_{CC(A)}=4.5V$ to $5.5V$; $I_O=-100\mu A$	$V_{CC(A)}-0.2$	$V_{CC(A)}$	-	V
			$V_{CC(A)}=4.5V$; $I_O=-12mA$	$V_{CC(A)}-0.5$	-	-	V
			$V_{CC(A)}=4.5V$; $I_O=-24mA$	$V_{CC(A)}-0.8$	-	-	V
LOW-level output voltage	V_{OL}	$V_I=V_{IH}$ or V_{IL}	$V_{CC(B)}=2.7V$ to $3.6V$; $I_O=100\mu A$	-	-	0.20	V
			$V_{CC(B)}=2.7V$; $I_O=12mA$	-	-	0.40	V
			$V_{CC(B)}=3.0V$; $I_O=24mA$	-	-	0.55	V
			$V_{CC(A)}=4.5V$ to $5.5V$; $I_O=100\mu A$	-	-	0.20	V



			$V_{CC(A)}=4.5V$; $I_O=12mA$	-	-	0.40	V
			$V_{CC(A)}=4.5V$; $I_O=24mA$	-	-	0.55	V
input leakage current	I_I	$V_I=5.5V$ or GND		-	-	± 5	μA
OFF-state output current	I_{OZ}	$V_I=V_{IH}$ or V_{IL} ^[2]	$V_{CC(B)}=3.6V$; $V_O=V_{CC(B)}$ or GND	-	-	± 5	μA
			$V_{CC(A)}=5.5V$; $V_O=V_{CC(A)}$ or GND	-	-	± 5	μA
supply current	I_{CC}	$I_O=0A$	$V_{CC(B)}=3.6V$; other inputs at $V_{CC(B)}$ or GND	-	-	10	μA
			$V_{CC(A)}=5.5V$; other inputs at $V_{CC(A)}$ or GND	-	-	10	μA
additional supply current	ΔI_{CC}	per control pin; $I_O=0A$ ^[3]	$V_{CC(B)}=2.7V$ to $3.6V$; $V_I=V_{CC(B)}-0.6V$; other inputs at $V_{CC(B)}$ or GND	-	-	500	μA
			$V_{CC(A)}=4.5V$ to $5.5V$; $V_I=V_{CC(A)}-0.6V$; other inputs at $V_{CC(A)}$ or GND	-	-	500	μA
input capacitance	C_I	-		-	4.0	-	pF
input/output capacitance	$C_{I/O}$	An and Bn		-	5.0	-	pF

Note:

[1] All typical values are measured at $V_{CC(A)}=5.0V$, $V_{CC(B)}=3.3V$ and $T_{amb}=25^\circ C$.

[2] For transceivers, the parameter I_{OZ} includes the input leakage current.

[3] $V_{CC(B)}=2.7V$ to $3.6V$: other inputs at $V_{CC(B)}$ or GND.

$V_{CC(A)}=4.5V$ to $5.5V$: other inputs at $V_{CC(A)}$ or GND.



3.3.2、DC Characteristics 2

($T_{amb} = -40^{\circ}\text{C}$ to $+125^{\circ}\text{C}$, voltages are referenced to GND (ground=0V), unless otherwise specified)

Parameter	Symbol	Conditions	Min.	Typ. ^[1]	Max.	Unit	
HIGH-level input voltage	V_{IH}	$V_{CC(B)} = 2.7\text{V}$ to 3.6V	2.0	-	-	V	
		$V_{CC(A)} = 4.5\text{V}$ to 5.5V	2.0	-	-	V	
LOW-level input voltage	V_{IL}	$V_{CC(B)} = 2.7\text{V}$ to 3.6V	-	-	0.8	V	
		$V_{CC(A)} = 4.5\text{V}$ to 5.5V	-	-	0.8	V	
HIGH-level output voltage	V_{OH}	$V_I = V_{IH}$ or V_{IL}	$V_{CC(B)} = 2.7\text{V}$ to 3.6V ; $I_O = -100\mu\text{A}$	$V_{CC(B)} - 0.3$	-	-	V
			$V_{CC(B)} = 2.7\text{V}$; $I_O = -12\text{mA}$	$V_{CC(B)} - 0.65$	-	-	V
			$V_{CC(B)} = 3.0\text{V}$; $I_O = -24\text{mA}$	$V_{CC(B)} - 1.0$	-	-	V
			$V_{CC(A)} = 4.5\text{V}$ to 5.5V ; $I_O = -100\mu\text{A}$	$V_{CC(A)} - 0.3$	-	-	V
			$V_{CC(A)} = 4.5\text{V}$; $I_O = -12\text{mA}$	$V_{CC(A)} - 0.65$	-	-	V
			$V_{CC(A)} = 4.5\text{V}$; $I_O = -24\text{mA}$	$V_{CC(A)} - 1.0$	-	-	V
LOW-level output voltage	V_{OL}	$V_I = V_{IH}$ or V_{IL}	$V_{CC(B)} = 2.7\text{V}$ to 3.6V ; $I_O = 100\mu\text{A}$	-	-	0.30	V
			$V_{CC(B)} = 2.7\text{V}$; $I_O = 12\text{mA}$	-	-	0.60	V
			$V_{CC(B)} = 3.0\text{V}$; $I_O = 24\text{mA}$	-	-	0.80	V
			$V_{CC(A)} = 4.5\text{V}$ to 5.5V ; $I_O = 100\mu\text{A}$	-	-	0.30	V
			$V_{CC(A)} = 4.5\text{V}$; $I_O = 12\text{mA}$	-	-	0.60	V
			$V_{CC(A)} = 4.5\text{V}$; $I_O = 24\text{mA}$	-	-	0.80	V
input leakage current	I_I	$V_I = 5.5\text{V}$ or GND	-	-	± 20	μA	
OFF-state output current	I_{OZ}	$V_I = V_{IH}$ or V_{IL} ^[2]	$V_{CC(B)} = 3.6\text{V}$; $V_O = V_{CC(B)}$ or GND	-	-	± 20	μA
			$V_{CC(A)} = 5.5\text{V}$; $V_O = V_{CC(A)}$ or GND	-	-	± 20	μA
supply current	I_{CC}	$I_O = 0\text{A}$	$V_{CC(B)} = 3.6\text{V}$; other inputs at $V_{CC(B)}$ or GND	-	-	40	μA
			$V_{CC(A)} = 5.5\text{V}$; other inputs at $V_{CC(A)}$ or GND	-	-	40	μA



additional supply current	ΔI_{CC}	per control pin; $I_O=0A$ ^[3]	$V_{CC(B)}=2.7V$ to $3.6V$; $V_I=V_{CC(B)}-0.6V$; other inputs at $V_{CC(B)}$ or GND	-	-	5000	μA
			$V_{CC(A)}=4.5V$ to $5.5V$; $V_I=V_{CC(A)}-0.6V$; other inputs at $V_{CC(A)}$ or GND	-	-	5000	μA

Note:

[1] All typical values are measured at $V_{CC(A)}=5.0V$, $V_{CC(B)}=3.3V$ and $T_{amb}=25^\circ C$.

[2] For transceivers, the parameter I_{OZ} includes the input leakage current.

[3] $V_{CC(B)}=2.7V$ to $3.6V$: other inputs at $V_{CC(B)}$ or GND.

$V_{CC(A)}=4.5V$ to $5.5V$: other inputs at $V_{CC(A)}$ or GND.

3.3.3. AC Characteristics 1

($T_{amb}=-40^\circ C$ to $+85^\circ C$, voltages are referenced to GND (ground=0V). $V_{CC(A)}=4.5V$ to $5.5V$; $t_r=t_f \leq 2.5ns$, unless otherwise specified)

Parameter	Symbol	Conditions	$V_{CC(B)}$	Min.	Typ. ^[1]	Max.	Unit
HIGH to LOW propagation delay	t_{PHL}	An to Bn; see Figure 5	2.7V	1.0	3.6	6.3	ns
			3.0V to 3.6V	1.0	3.3	6.3	ns
		Bn to An; see Figure 5	2.7V	1.0	3.4	6.1	ns
			3.0V to 3.6V	1.0	3.4	6.1	ns
LOW to HIGH propagation delay	t_{PLH}	An to Bn; see Figure 5	2.7V	1.0	3.3	6.7	ns
			3.0V to 3.6V	1.0	2.8	6.5	ns
		Bn to An; see Figure 5	2.7V	1.0	3.0	5.0	ns
			3.0V to 3.6V	1.0	3.0	5.0	ns
OFF-state to LOW propagation delay	t_{PZL}	\overline{OE} to An; see Figure 6	2.7V	1.0	4.5	9.0	ns
			3.0V to 3.6V	1.0	4.5	9.0	ns
		\overline{OE} to Bn; see Figure 6	2.7V	1.0	4.4	8.7	ns
			3.0V to 3.6V	1.0	3.8	8.1	ns
OFF-state to HIGH propagation delay	t_{PZH}	\overline{OE} to An; see Figure 6	2.7V	1.0	4.5	8.1	ns
			3.0V to 3.6V	1.0	4.5	8.1	ns
		\overline{OE} to Bn; see Figure 6	2.7V	1.0	4.3	8.7	ns
			3.0V to 3.6V	1.0	3.2	8.1	ns
LOW to OFF-state propagation delay	t_{PLZ}	\overline{OE} to An; see Figure 6	2.7V	1.0	2.9	7.0	ns
			3.0V to 3.6V	1.0	2.9	7.0	ns
		\overline{OE} to Bn; see Figure 6	2.7V	1.0	3.9	7.7	ns
			3.0V to 3.6V	1.0	3.5	7.7	ns
HIGH to OFF-state propagation delay	t_{PHZ}	\overline{OE} to An; see Figure 6	2.7V	1.0	2.8	5.8	ns
			3.0V to 3.6V	1.0	2.8	5.8	ns
		\overline{OE} to Bn; see Figure 6	2.7V	1.0	3.3	7.8	ns
			3.0V to 3.6V	1.0	2.9	7.8	ns
output skew time	$t_{sk(o)}$	-	_ [2]	-	-	1.0	ns



Power dissipation capacitance	C_{PD}	5V bus: Bn to An; $V_I=GND$ to $V_{CC(A)}$; $V_{CC(A)}=5.0V^{[3]}$	outputs enabled	-	-	17	-	pF
			outputs disabled	-	-	5	-	pF
		3V bus: An to Bn; $V_I=GND$ to $V_{CC(B)}$; $V_{CC(B)}=3.3V^{[3]}$	outputs enabled	-	-	17	-	pF
			outputs disabled	-	-	5	-	pF

Note:

[1] Typical values are measured at $T_{amb}=25^{\circ}C$, $V_{CC(A)}=5.0V$, and $V_{CC(B)}=2.7V$ and $3.3V$ respectively.

[2] Skew between any two outputs of the same package switching in the same direction. This parameter is guaranteed by design.

[3] C_{PD} is used to determine the dynamic power dissipation (P_D in uW).

$$P_D=C_{PD} \times V_{CC}^2 \times f_i \times N + \sum(C_L \times V_{CC}^2 \times f_o) \text{ where:}$$

f_i =input frequency in MHz; f_o =output frequency in MHz

C_L =output load capacitance in pF

V_{CC} =supply voltage in Volts

N =number of inputs switching

$\sum(C_L \times V_{CC}^2 \times f_o)$ =sum of the outputs

3.3.4、AC Characteristics 2

($T_{amb}=-40^{\circ}C$ to $+125^{\circ}C$, voltages are referenced to GND (ground=0V). $V_{CC(A)}=4.5V$ to $5.5V$; $t_r=t_f \leq 2.5ns$, unless otherwise specified)

Parameter	Symbol	Conditions	$V_{CC(B)}$	Min.	Typ. ^[1]	Max.	Unit
HIGH to LOW propagation delay	t_{PHL}	An to Bn; see Figure 5	2.7V	1.0	-	8.0	ns
			3.0V to 3.6V	1.0	-	8.0	ns
		Bn to An; see Figure 5	2.7V	1.0	-	8.0	ns
			3.0V to 3.6V	1.0	-	8.0	ns
LOW to HIGH propagation delay	t_{PLH}	An to Bn; see Figure 5	2.7V	1.0	-	8.5	ns
			3.0V to 3.6V	1.0	-	8.5	ns
		Bn to An; see Figure 5	2.7V	1.0	-	6.5	ns
			3.0V to 3.6V	1.0	-	6.5	ns
OFF-state to LOW propagation delay	t_{PZL}	$\overline{\text{OE}}$ to An; see Figure 6	2.7V	1.0	-	11.5	ns
			3.0V to 3.6V	1.0	-	11.5	ns
		$\overline{\text{OE}}$ to Bn; see Figure 6	2.7V	1.0	-	11.0	ns
			3.0V to 3.6V	1.0	-	10.5	ns
OFF-state to HIGH propagation delay	t_{PZH}	$\overline{\text{OE}}$ to An; see Figure 6	2.7V	1.0	-	10.5	ns
			3.0V to 3.6V	1.0	-	10.5	ns
		$\overline{\text{OE}}$ to Bn; see Figure 6	2.7V	1.0	-	11.0	ns
			3.0V to 3.6V	1.0	-	10.5	ns
LOW to OFF-state propagation delay	t_{PLZ}	$\overline{\text{OE}}$ to An; see Figure 6	2.7V	1.0	-	9.0	ns
			3.0V to 3.6V	1.0	-	9.0	ns
		$\overline{\text{OE}}$ to Bn; see Figure 6	2.7V	1.0	-	10.0	ns
			3.0V to 3.6V	1.0	-	10.0	ns
HIGH to	t_{PHZ}	$\overline{\text{OE}}$ to An; see Figure 6	2.7V	1.0	-	7.5	ns



OFF-state propagation delay		$\overline{\text{OE}}$ to Bn; see Figure 6	3.0V to 3.6V	1.0	-	7.5	ns
			2.7V	1.0	-	10.0	ns
			3.0V to 3.6V	1.0	-	10.0	ns
output skew time	$t_{sk(o)}$	-	_[2]	-	-	1.5	ns

Note:

[1] Typical values are measured at $T_{amb}=25^{\circ}\text{C}$, $V_{CC(A)}=5.0\text{V}$, and $V_{CC(B)}=2.7\text{V}$ and 3.3V respectively.

[2] Skew between any two outputs of the same package switching in the same direction. This parameter is guaranteed by design.

4、Testing Circuit

4.1、AC Testing Circuit

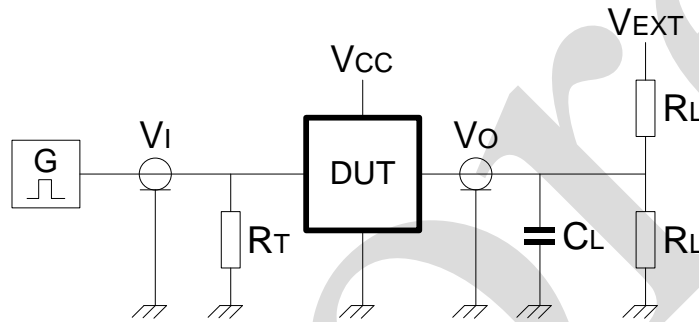

Figure 3. Load circuitry for switching times

Definitions for test circuit:

R_L =Load resistance.

C_L =Load capacitance including jig and probe capacitance.

R_T =Termination resistance should be equal to output impedance Z_o of the pulse generator.

4.2、Test Data

Supply voltage		Input	Load		V_{EXT}		
$V_{CC(A)}$	$V_{CC(B)}$	$V_I^{[1]}$	C_L	R_L	t_{PLH}, t_{PHL}	t_{PZH}, t_{PHZ}	$t_{PZL}, t_{PLZ}^{[2]}$
< 2.7 V	< 2.7 V	V_{CCI}	50pF	500Ω	open	GND	$2 \times V_{CCO}$
-	2.7V to 3.6V	2.7V	50pF	500Ω	open	GND	$2 \times V_{CCO}$
4.5V to 5.5V	-	3.0V	50pF	500Ω	open	GND	$2 \times V_{CCO}$

Note:

[1] V_{CCI} is the supply voltage associated with the data input port.

[2] V_{CCO} is the supply voltage associated with the output port.



4.3、AC Testing Waveforms

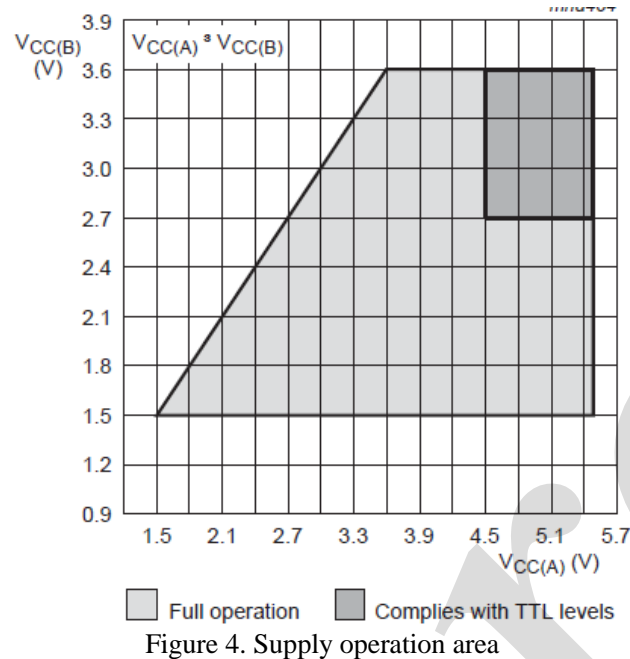
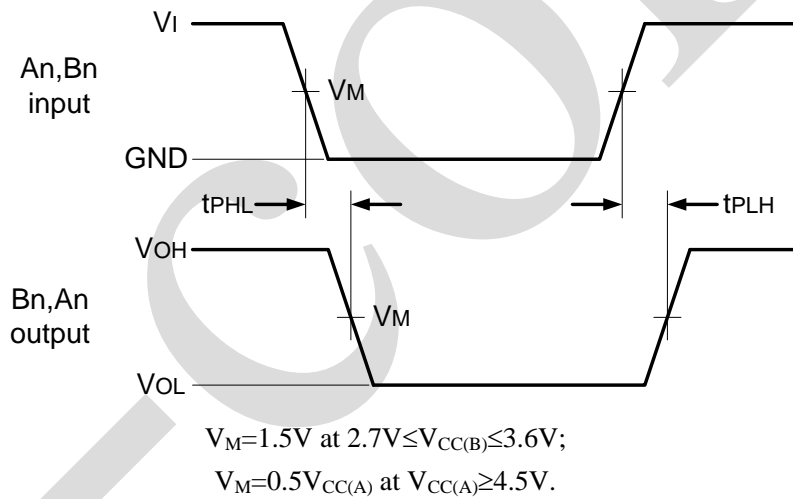
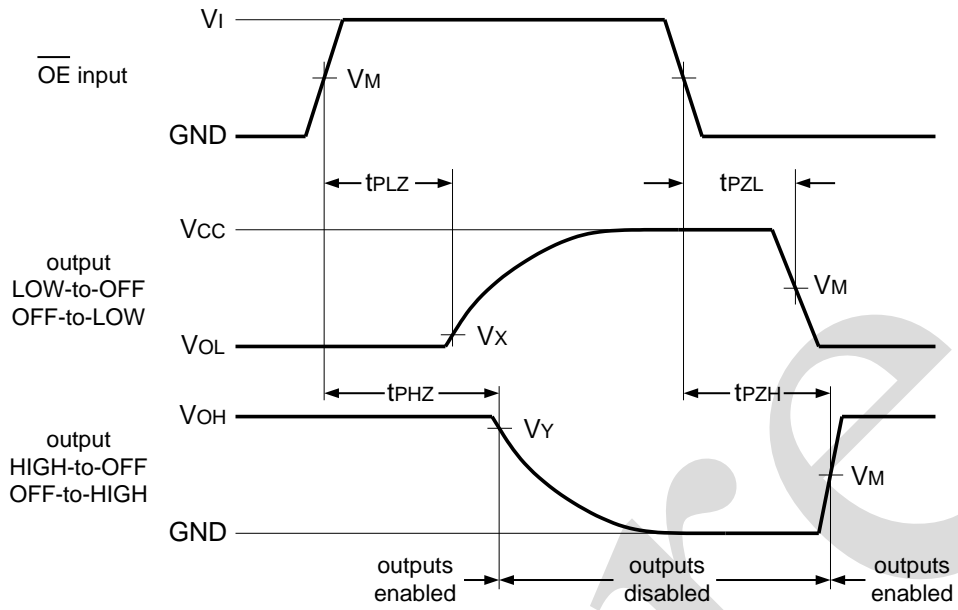

Figure 4. Supply operation area



V_{OL} and V_{OH} are typical output voltage drops that occur with the output load.

Figure 5. Input (An, Bn) to output (Bn, An) propagation delays



$$V_M = 1.5V \text{ at } 2.7V \leq V_{CC(B)} \leq 3.6V;$$

$$V_M = 0.5V_{CC(A)} \text{ at } V_{CC(A)} \geq 4.5V.$$

$$V_x = V_{OL} + 0.3V \text{ at } V_{CC(B)} \geq 2.7V;$$

$$V_y = V_{OH} - 0.3V \text{ at } V_{CC(B)} \geq 2.7V.$$

V_{OL} and V_{OH} are typical output voltage drops that occur with the output load.

Figure 6. 3-state enable and disable times



5、Package Information

5.1、SOP24

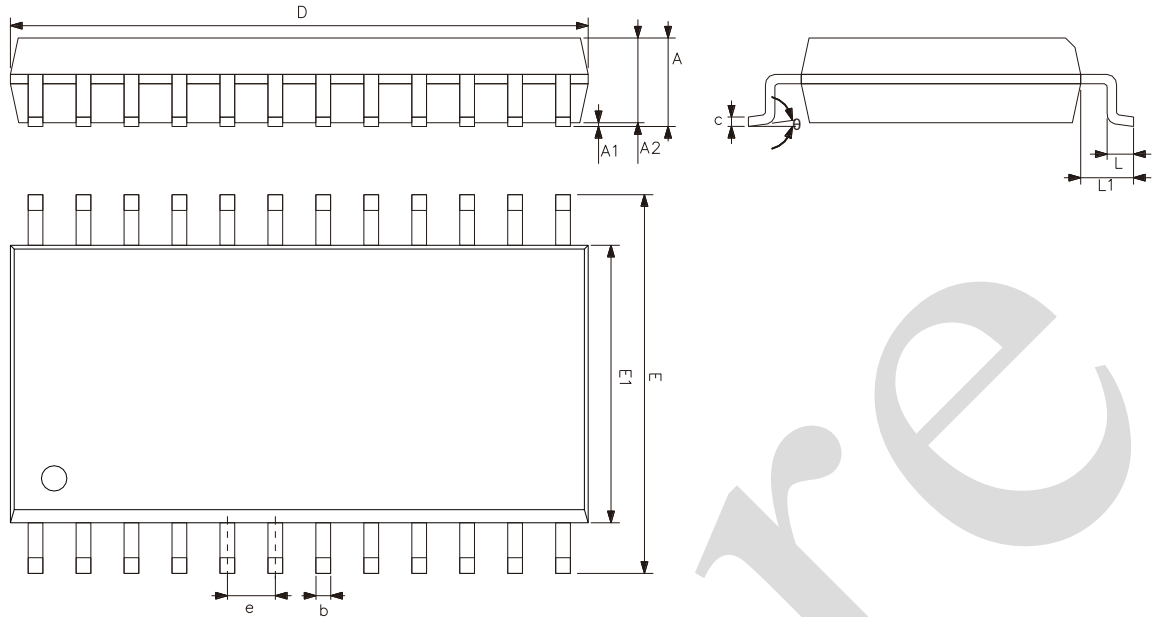

Symbol	Dimensions (mm)	
	Min.	Max.
A	2.35	2.65
A1	0.10	0.30
A2	2.13	2.44
b	0.39	0.47
c	0.25	0.30
D	15.19	15.55
E	10.10	10.57
E1	7.40	7.62
e	1.27	
L	0.41	1.00
L1	1.30	1.50
θ	0°	8°



5.2、SSOP24

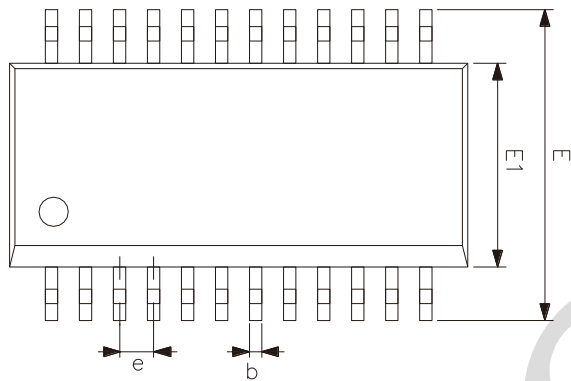
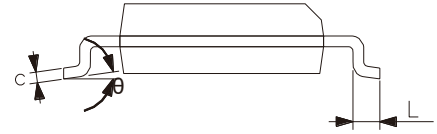
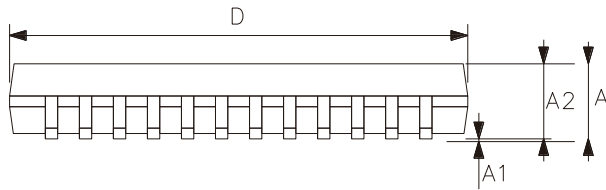

Symbol	Dimensions (mm)	
	Min.	Max.
A	1.35	1.75
A1	0.10	0.25
A2	1.30	1.55
b	0.23	0.47
c	0.19	0.26
D	8.45	8.85
E	5.80	6.20
E1	3.70	4.10
e	0.635	
L	0.40	0.80
θ	0°	8°



5.3、TSSOP24

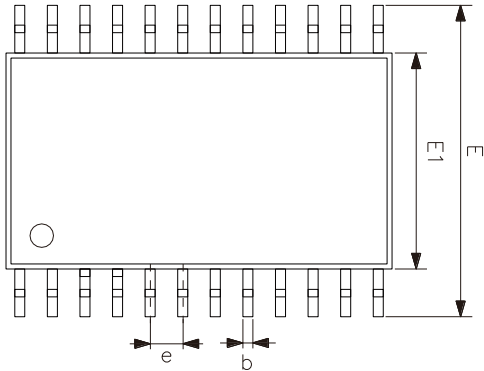
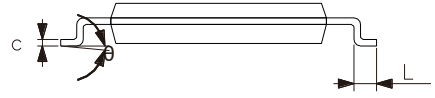
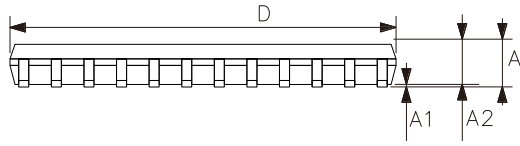

Symbol	Dimensions (mm)	
	Min.	Max.
A	-	1.20
A1	0.05	0.15
A2	0.80	1.05
b	0.19	0.30
c	0.09	0.20
D	7.70	7.90
E	6.20	6.60
E1	4.30	4.50
e	0.65	
L	0.45	0.75
θ	0°	8°



5.4. DHVQFN24

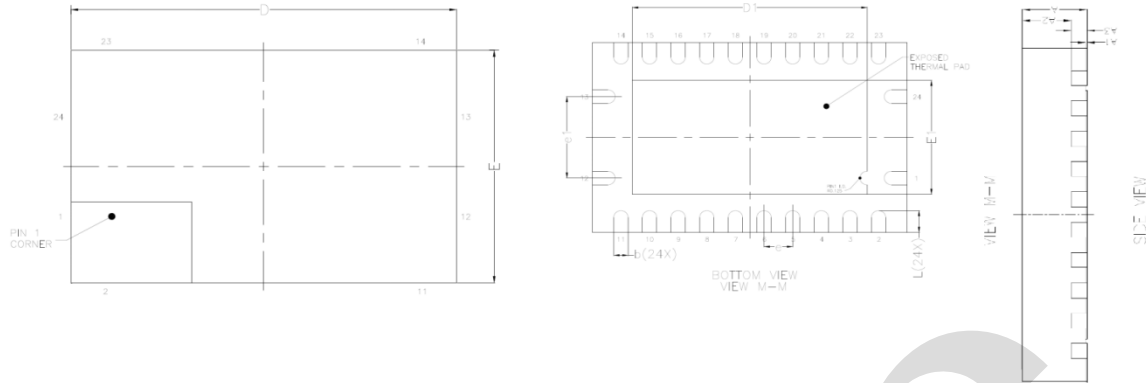

Symbol	Dimensions (mm)	
	Min.	Max.
A	0.80	1.00
A1	0.00	0.05
A2	0.60	0.70
A3	0.20	
D	5.40	5.60
E	3.40	3.60
e	0.50	
e1	1.50	
b	0.18	0.30
L	0.30	0.50
D1	3.95	4.25
E1	1.95	2.25



6、 Statements And Notes

6.1、 The name and content of Hazardous substances or Elements in the product

Part name	Hazardous substances or Elements									
	Lead and lead compounds	Mercury and mercury compounds	Cadmium and cadmium compounds	Hexavalent chromium compounds	Polybrominated biphenyls	Polybrominated biphenyl ethers	Dibutyl phthalate	Butylbenzyl phthalate	Di-2-ethylhexyl phthalate	Diisobutyl phthalate
Lead frame	○	○	○	○	○	○	○	○	○	○
Plastic resin	○	○	○	○	○	○	○	○	○	○
Chip	○	○	○	○	○	○	○	○	○	○
The lead	○	○	○	○	○	○	○	○	○	○
Plastic sheet installed	○	○	○	○	○	○	○	○	○	○
explanation	○: Indicates that the content of hazardous substances or elements in the detection limit of the following the SJ/T11363-2006 standard. ×: Indicates that the content of hazardous substances or elements exceeding the SJ/T11363-2006 Standard limit requirements.									

6.2、 Notes

We Recommend you to read this chapter carefully before using this product.

The information in this chapter is provided for reference only and i-Core disclaims any express or implied warranties, including but not limited to applicability, special application or non-infringement of third party rights.

This product is not suitable for critical equipment such as life-saving, life-sustaining or safety equipment. It is also not suitable for applications that may result in personal injury, death, or serious property or environmental damage due to product malfunction or failure. I-Core will not be liable for any damages incurred by the customers at their own risk for such applications.

The customer is responsible for conducting all necessary tests i-Core's application to avoid failure in the application or the application of the customer's third party users. I-Core does not accept any liability.

The Company reserves the right to change or improve the information published in this chapter at any time.

The information in this chapter are subject to change without notice. We recommend the customer to consult our sales staff before purchasing.

Please obtain related materials form i-Core's regular channels and we are not responsible for its content if it is provided by sources other than our company.

In case of any conflict between the Chinese and English version, the version is subject to the Chinese one.