



AiP74LV541

Octal Buffer/Line Driver; 3-State

Product Specification

Specification Revision History:

Version	Date	Description
2025-11-A0	2025-11	New
2026-03-A1	2026-03	Modify the parameters



Contents

1、 General Description.....	3
2、 Block Diagram And Pin Description	5
2.1、 Block Diagram	5
2.2、 Pin Configurations.....	6
2.3、 Pin Description	6
2.4、 Function Table.....	7
3、 Electrical Parameter	7
3.1、 Absolute Maximum Ratings.....	7
3.2、 Recommended Operating Conditions.....	7
3.3、 Electrical Characteristics	8
3.3.1、 DC Characteristics 1	8
3.3.2、 DC Characteristics 2	9
3.3.3、 AC Characteristics 1	10
3.3.4、 AC Characteristics 2	11
4、 Testing Circuit	12
4.1、 AC Testing Circuit	12
4.2、 AC Testing Waveforms.....	12
4.3、 Measurement Points	13
4.4、 Test Data	13
5、 Package Information	14
5.1、 DIP20	14
5.2、 SOP20	15
5.3、 TSSOP20.....	16
6、 Statements And Notes	17
6.1、 The name and content of Hazardous substances or Elements in the product	17
6.2、 Notes	17



1、 General Description

The AiP74LV541 is an 8-bit buffer/line driver with 3-state outputs. The device features two output enables ($\overline{OE1}$ and $\overline{OE2}$). A HIGH on $\overline{OE}n$ causes the associated outputs to assume a high-impedance OFF-state.

Features:

- Operating voltage: 2.0V to 5.5V
- 5.5V tolerant inputs/outputs
- Power-down mode
- Specified from -40°C to +125°C
- Packaging information: DIP20/SOP20/TSSOP20



Ordering Information:

Tube packing specifications:

Part number	Packaging form	Marking code	Tube quantity	Boxed tube quantity	Boxed quantity	Notes	Moisture sensitivity level
AiP74LV541DA20.TB	DIP20	74LV541	18 PCS/tube	40 tube/box	720 PCS/box	Dimensions of plastic enclosure: 26.3mm×6.4mm Pin spacing: 2.54mm	-
AiP74LV541SA20.TB	SOP20	74LV541	35 PCS/tube	80 tube/box	2800 PCS/box	Dimensions of plastic enclosure: 12.8mm×7.5mm Pin spacing: 1.27mm	MSL3

Reel packing specifications:

Part number	Packaging form	Marking code	Reel quantity	Boxed reel quantity	Notes	Moisture sensitivity level
AiP74LV541SA20.TR	SOP20	74LV541	2000 PCS/reel	2000 PCS/box	Dimensions of plastic enclosure: 12.8mm×7.5mm Pin spacing: 1.27mm	MSL3
AiP74LV541TA20.TR	TSSOP20	74LV541	4000 PCS/reel	8000 PCS/box	Dimensions of plastic enclosure: 6.5mm×4.4mm Pin spacing: 0.65mm	MSL3

Note: If the physical information is inconsistent with the ordering information, please refer to the actual product.



2、Block Diagram And Pin Description

2.1、Block Diagram

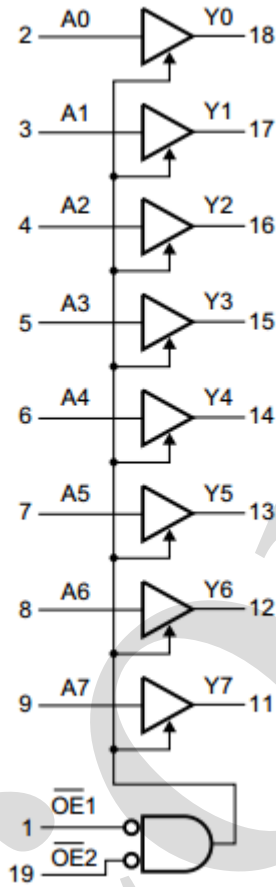

Figure 1. Logic symbol

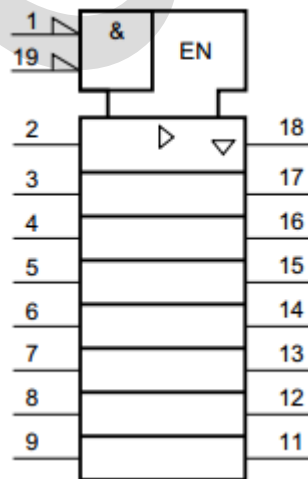
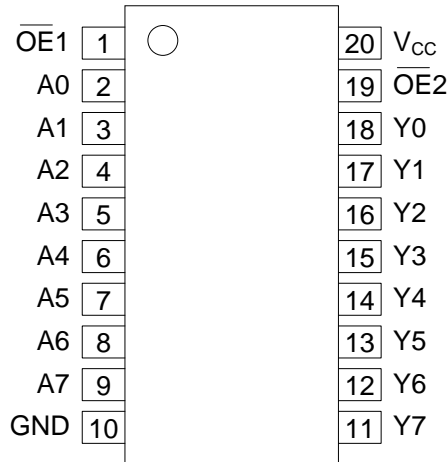

Figure 2. IEC logic symbol



2.2、Pin Configurations



2.3、Pin Description

Pin No.	Pin Name	Description
1	$\overline{OE1}$	output enable input (active LOW)
2	A0	data input
3	A1	data input
4	A2	data input
5	A3	data input
6	A4	data input
7	A5	data input
8	A6	data input
9	A7	data input
10	GND	ground (0V)
11	Y7	data output
12	Y6	data output
13	Y5	data output
14	Y4	data output
15	Y3	data output
16	Y2	data output
17	Y1	data output
18	Y0	data output
19	$\overline{OE2}$	output enable input (active LOW)
20	V_{CC}	supply voltage



2.4、Function Table

Control		Input	Output
OE1	OE2	An	Yn
L	L	L	L
L	L	H	H
X	H	X	Z
H	X	X	Z

Note: H=HIGH voltage level; L=LOW voltage level; X=don't care; Z=high-impedance OFF-state.

3、Electrical Parameter

3.1、Absolute Maximum Ratings

(Voltages are referenced to GND (ground=0V), unless otherwise specified.)

Parameter	Symbol	Conditions	Min.	Max.	Unit
supply voltage	V_{CC}	-	-0.5	+7.0	V
input clamping current	I_{IK}	$V_I < -0.5V$ or $V_I > V_{CC}+0.5V$	-	± 20	mA
output clamping current	I_{OK}	$V_O < -0.5V$ or $V_O > V_{CC}+0.5V$	-	± 50	mA
output current	I_O	$-0.5V < V_O < V_{CC}+0.5V$	-	± 35	mA
supply current	I_{CC}	-	-	70	mA
ground current	I_{GND}	-	-70	-	mA
storage temperature	T_{stg}	-	-65	+150	°C
total power dissipation	P_{tot}	-	-	500	mW
soldering temperature	T_L	10s	DIP	245	°C
			SOP/TSSOP	260	
electrostatic discharge	ESD	HBM	2000		V

Note:

[1] Stresses beyond those listed may cause permanent damage to the device. These are stress ratings only and functional operation of the device at these or any other conditions beyond those indicated under “recommended operating conditions” is not implied. Exposure to absolute-maximum-rated conditions for extended periods may affect device reliability.

3.2、Recommended Operating Conditions

Parameter	Symbol	Conditions	Min.	Typ.	Max.	Unit
supply voltage	V_{CC}	-	2.0	-	5.5	V
input voltage	V_I	-	0	-	V_{CC}	V
output voltage	V_O	-	0	-	V_{CC}	V
ambient temperature	T_{amb}	-	-40	-	+125	°C
input transition rise and fall rate	$\Delta t/\Delta V$	$V_{CC}=2.3V$ to $2.7V$	-	-	200	ns/V
		$V_{CC}=3V$ to $3.6V$	-	-	100	ns/V
		$V_{CC}=4.5V$ to $5.5V$	-	-	20	ns/V

Note: The LV is guaranteed to function down to $V_{CC}=1.0V$ (input levels GND or V_{CC}); DC characteristics are guaranteed from $V_{CC}=1.2V$ to $V_{CC}=5.5V$.



3.3、Electrical Characteristics

3.3.1、DC Characteristics 1

($T_{amb}=-40^{\circ}\text{C}$ to $+85^{\circ}\text{C}$, voltages are referenced to GND (ground=0V), unless otherwise specified.)

Parameter	Symbol	Conditions	Min.	Typ.	Max.	Unit	
HIGH-level input voltage	V_{IH}	$V_{CC}=2V$	1.5	-	-	V	
		$V_{CC}=2.3V$ to $2.7V$	$0.7 \times V_{CC}$	-	-	V	
		$V_{CC}=3.0V$ to $3.6V$	$0.7 \times V_{CC}$	-	-	V	
		$V_{CC}=4.5V$ to $5.5V$	$0.7 \times V_{CC}$	-	-	V	
LOW-level input voltage	V_{IL}	$V_{CC}=2V$	-	-	0.5	V	
		$V_{CC}=2.3V$ to $2.7V$	-	-	$0.3 \times V_{CC}$	V	
		$V_{CC}=3.0V$ to $3.6V$	-	-	$0.3 \times V_{CC}$	V	
		$V_{CC}=4.5V$ to $5.5V$	-	-	$0.3 \times V_{CC}$	V	
HIGH-level output voltage	V_{OH}	$V_I = V_{IH}$ or V_{IL}	$I_O=-50\mu A$; $V_{CC}=2V$ to $5.5V$	$V_{CC}-0.1$	-	-	V
			$I_O=-2mA$; $V_{CC}=2.3V$	2	-	-	V
			$I_O=-8mA$; $V_{CC}=3.0V$	2.48	-	-	V
			$I_O=-16mA$; $V_{CC}=4.5V$	3.8	-	-	V
LOW-level output voltage	V_{OL}	$V_I = V_{IH}$ or V_{IL}	$I_O=50\mu A$; $V_{CC}=2V$ to $5.5V$	-	-	0.1	V
			$I_O=2mA$; $V_{CC}=2.3V$	-	-	0.4	V
			$I_O=8mA$; $V_{CC}=3.0V$	-	-	0.44	V
			$I_O=16mA$; $V_{CC}=4.5V$	-	-	0.55	V
input leakage current	I_I	$V_I=V_{CC}$ or GND; $V_{CC}=0V$ to $5.5V$	-	-	± 1	μA	
OFF-state output current	I_{OZ}	$V_I=V_{IH}$ or V_{IL} ; $V_O=$ GND to $5.5V$; $V_{CC}=5.5V$	-	-	± 2.5	μA	
power-off leakage current	I_{OFF}	V_I or $V_O=$ GND to $5.5V$; $V_{CC}=0V$ to $5.5V$	-	-	5	μA	
supply current	I_{CC}	$V_I=V_{CC}$ or GND; $I_O=0A$; $V_{CC}=5.5V$	-	-	20	μA	

Note: All typical values are measured at $T_{amb}=25^{\circ}\text{C}$



3.3.2、DC Characteristics 2

($T_{amb}=-40^{\circ}\text{C}$ to $+125^{\circ}\text{C}$, voltages are referenced to GND (ground=0V), unless otherwise specified.)

Parameter	Symbol	Conditions	Min.	Typ.	Max.	Unit	
HIGH-level input voltage	V_{IH}	$V_{CC}=2\text{V}$	1.5	-	-	V	
		$V_{CC}=2.3\text{V}$ to 2.7V	$0.7 \times V_{CC}$	-	-	V	
		$V_{CC}=3.0\text{V}$ to 3.6V	$0.7 \times V_{CC}$	-	-	V	
		$V_{CC}=4.5\text{V}$ to 5.5V	$0.7 \times V_{CC}$	-	-	V	
LOW-level input voltage	V_{IL}	$V_{CC}=2\text{V}$	-	-	0.5	V	
		$V_{CC}=2.3\text{V}$ to 2.7V	-	-	$0.3 \times V_{CC}$	V	
		$V_{CC}=3.0\text{V}$ to 3.6V	-	-	$0.3 \times V_{CC}$	V	
		$V_{CC}=4.5\text{V}$ to 5.5V	-	-	$0.3 \times V_{CC}$	V	
HIGH-level output voltage	V_{OH}	$V_I = V_{IH}$ or V_{IL}	$I_O=-50\mu\text{A}$; $V_{CC}=2\text{V}$ to 5.5V	$V_{CC}-0.1$	-	-	V
			$I_O=-2\text{mA}$; $V_{CC}=2.3\text{V}$	2	-	-	V
			$I_O=-8\text{mA}$; $V_{CC}=3.0\text{V}$	2.48	-	-	V
			$I_O=-16\text{mA}$; $V_{CC}=4.5\text{V}$	3.8	-	-	V
LOW-level output voltage	V_{OL}	$V_I = V_{IH}$ or V_{IL}	$I_O=50\mu\text{A}$; $V_{CC}=2\text{V}$ to 5.5V	-	-	0.1	V
			$I_O=2\text{mA}$; $V_{CC}=2.3\text{V}$	-	-	0.4	V
			$I_O=8\text{mA}$; $V_{CC}=3.0\text{V}$	-	-	0.44	V
			$I_O=16\text{mA}$; $V_{CC}=4.5\text{V}$	-	-	0.55	V
input leakage current	I_I	$V_I=V_{CC}$ or GND; $V_{CC}=0\text{V}$ to 5.5V	-	-	± 1	μA	
OFF-state output current	I_{OZ}	$V_I=V_{IH}$ or V_{IL} ; $V_O=$ GND to 5.5V ; $V_{CC}=5.5\text{V}$	-	-	± 2.5	μA	
power-off leakage current	I_{OFF}	V_I or $V_O=$ GND to 5.5V ; $V_{CC}=0\text{V}$ to 5.5V	-	-	5	μA	
supply current	I_{CC}	$V_I=V_{CC}$ or GND; $I_O=0\text{A}$; $V_{CC}=5.5\text{V}$	-	-	20	μA	

Note: All typical values are measured at $T_{amb}=25^{\circ}\text{C}$



3.3.3、 AC Characteristics 1

($T_{amb}=-40^{\circ}C$ to $+85^{\circ}C$, $GND=0V$; $t_r=t_f=3ns$; $C_L=15pF$ or $50pF$; $R_L=500\Omega$, unless otherwise specified.)

Parameter	Symbol	Conditions	Min.	Typ.	Max.	Unit	
An to Yn; propagation delay	t_{PHL}/t_{PLH}	see Figure 4, 5	$V_{CC}=2.3V$ to $2.7V$; $C_L=15pF$	1	-	13.5	ns
			$V_{CC}=2.3V$ to $2.7V$; $C_L=50pF$	1	-	18.5	ns
			$V_{CC}=3V$ to $3.6V$; $C_L=15pF$	1	-	8.5	ns
			$V_{CC}=3V$ to $3.6V$; $C_L=50pF$	1	-	12	ns
			$V_{CC}=4.5V$ to $5.5V$; $C_L=15pF$	1	-	6	ns
			$V_{CC}=4.5V$ to $5.5V$; $C_L=50pF$	1	-	8	ns
\overline{OEn} to Yn; 3-state output enable time	t_{PZH}/t_{PZL}	see Figure 4, 5	$V_{CC}=2.3V$ to $2.7V$; $C_L=15pF$	1	-	19.5	ns
			$V_{CC}=2.3V$ to $2.7V$; $C_L=50pF$	1	-	24	ns
			$V_{CC}=3V$ to $3.6V$; $C_L=15pF$	1	-	12.5	ns
			$V_{CC}=3V$ to $3.6V$; $C_L=50pF$	1	-	16	ns
			$V_{CC}=4.5V$ to $5.5V$; $C_L=15pF$	1	-	8.5	
			$V_{CC}=4.5V$ to $5.5V$; $C_L=50pF$	1	-	10.5	ns
\overline{OEn} to Yn; 3-state output disable time	t_{PHZ}/t_{PLZ}	see Figure 4, 5	$V_{CC}=2.3V$ to $2.7V$; $C_L=15pF$	1	-	15	ns
			$V_{CC}=2.3V$ to $2.7V$; $C_L=50pF$	1	-	20	ns
			$V_{CC}=3V$ to $3.6V$; $C_L=15pF$	1	-	12	ns
			$V_{CC}=3V$ to $3.6V$; $C_L=50pF$	1	-	17.5	
			$V_{CC}=4.5V$ to $5.5V$; $C_L=15pF$	1	-	8	ns
			$V_{CC}=4.5V$ to $5.5V$; $C_L=50pF$	1	-	10	ns

Note:

[1] Unless otherwise stated, all typical values are measured at $T_{amb}=25^{\circ}C$.

[2] Typical values are measured at $V_{CC}=3.3V$.

[3] C_{PD} is used to determine the dynamic power dissipation (P_D in uW).

$$P_D = C_{PD} \times V_{CC}^2 \times f_i + \sum (C_L \times V_{CC}^2 \times f_o) \text{ where:}$$

f_i =input frequency in MHz;

f_o =output frequency in MHz;

C_L =output load capacitance in pF;

V_{CC} =supply voltage in V;

$\sum (C_L \times V_{CC}^2 \times f_o)$ =sum of outputs.



3.3.4、AC Characteristics 2

($T_{amb}=-40^{\circ}C$ to $+125^{\circ}C$, $GND=0V$; $t_r=t_f=3ns$; $C_L=15pF$ or $50pF$; $R_L=500\Omega$, unless otherwise specified.)

Parameter	Symbol	Conditions	Min.	Typ.	Max.	Unit	
nA to nY; propagation delay	t_{PHL}/t_{PLH}	see Figure 4, 5	$V_{CC}=2.3V$ to $2.7V$; $C_L=15pF$	1	-	13.5	ns
			$V_{CC}=2.3V$ to $2.7V$; $C_L=50pF$	1	-	18.5	ns
			$V_{CC}=3V$ to $3.6V$; $C_L=15pF$	1	-	8.5	ns
			$V_{CC}=3V$ to $3.6V$; $C_L=50pF$	1	-	12	ns
			$V_{CC}=4.5V$ to $5.5V$; $C_L=15pF$	1	-	6	ns
			$V_{CC}=4.5V$ to $5.5V$; $C_L=50pF$	1	-	8	ns
nOE to nY; 3-state output enable time	t_{PZH}/t_{PZL}	see Figure 4, 5	$V_{CC}=2.3V$ to $2.7V$; $C_L=15pF$	1	-	19.5	ns
			$V_{CC}=2.3V$ to $2.7V$; $C_L=50pF$	1	-	24	ns
			$V_{CC}=3V$ to $3.6V$; $C_L=15pF$	1	-	12.5	ns
			$V_{CC}=3V$ to $3.6V$; $C_L=50pF$	1	-	16	ns
			$V_{CC}=4.5V$ to $5.5V$; $C_L=15pF$	1	-	8.5	
			$V_{CC}=4.5V$ to $5.5V$; $C_L=50pF$	1	-	10.5	ns
nOE to nY; 3-state output disable time	t_{PHZ}/t_{PLZ}	see Figure 4, 5	$V_{CC}=2.3V$ to $2.7V$; $C_L=15pF$	1	-	15	ns
			$V_{CC}=2.3V$ to $2.7V$; $C_L=50pF$	1	-	20	ns
			$V_{CC}=3V$ to $3.6V$; $C_L=15pF$	1	-	12	ns
			$V_{CC}=3V$ to $3.6V$; $C_L=50pF$	1	-	17.5	
			$V_{CC}=4.5V$ to $5.5V$; $C_L=15pF$	1	-	8	ns
			$V_{CC}=4.5V$ to $5.5V$; $C_L=50pF$	1	-	10	ns

Note:

[1] Unless otherwise stated, all typical values are measured at $T_{amb}=25^{\circ}C$.

[2] Typical values are measured at $V_{CC}=3.3V$.



4、Testing Circuit

4.1、AC Testing Circuit

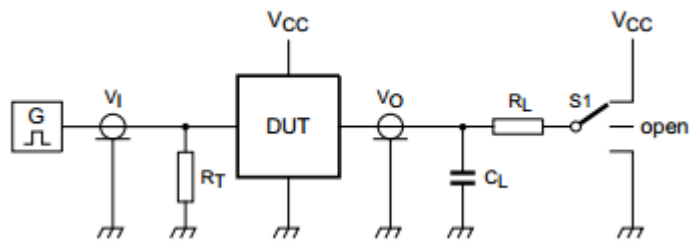

Figure 3. Load circuit for switching times

Definitions for test circuit:

R_L =Load resistance.

C_L =Load capacitance including jig and probe capacitance.

R_T =Termination resistance should be equal to the output impedance Z_o of the pulse generator.

4.2、AC Testing Waveforms

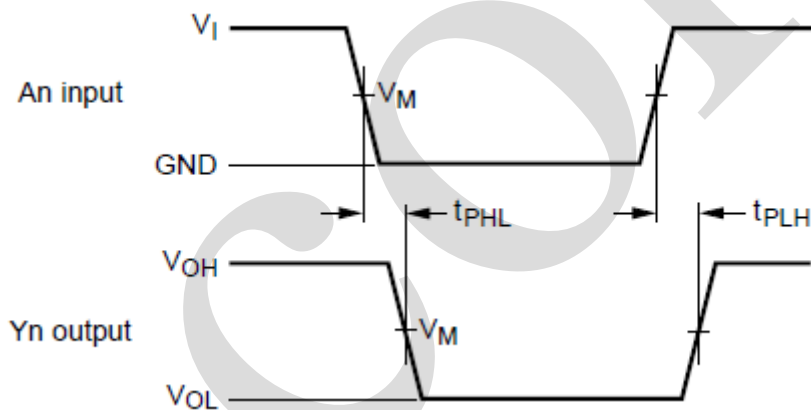

Figure 4. The input (An) to output (Yn) propagation delays

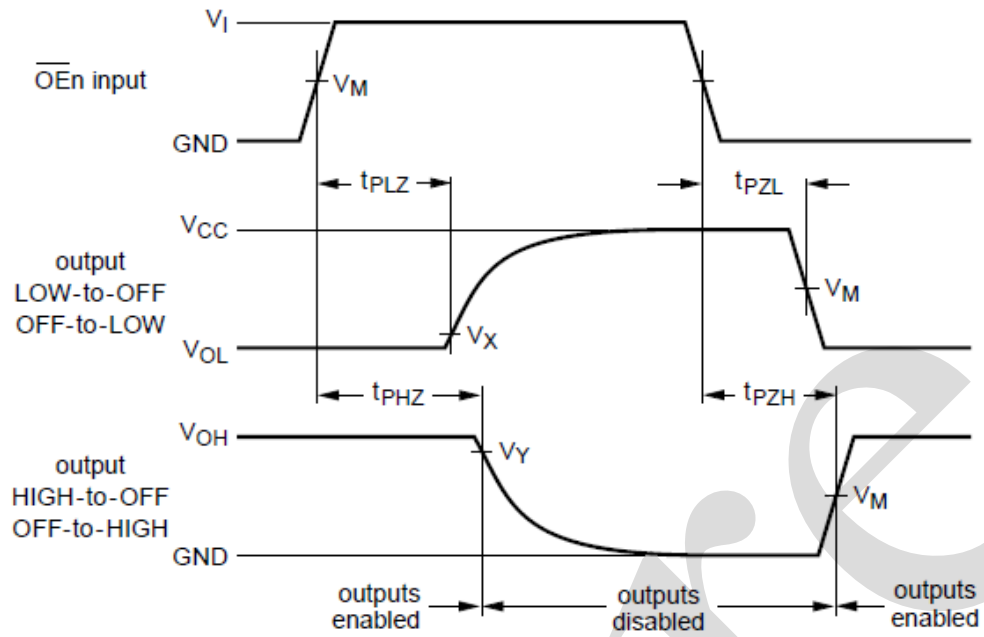

Figure 5. Enable and disable times

4.3. Measurement Points

Supply voltage	Input	Output		
V_{CC}	V_M	V_M	V_X	V_Y
2.7V to 5.5V	$0.5 \times V_{CC}$	$0.5 \times V_{CC}$	$V_{OL} + 0.3V$	$V_{OH} - 0.3V$

4.4. Test Data

Supply voltage	Input		Load		S1 position		
V_{CC}	V_I	t_r, t_f	C_L	R_L	t_{PHL}, t_{PLH}	t_{PZH}, t_{PHZ}	t_{PZL}, t_{PLZ}
2.7V to 5.5V	GND to V_{CC}	3ns	15pF, 50pF	1k Ω	open	GND	V_{CC}



5、Package Information

5.1、DIP20

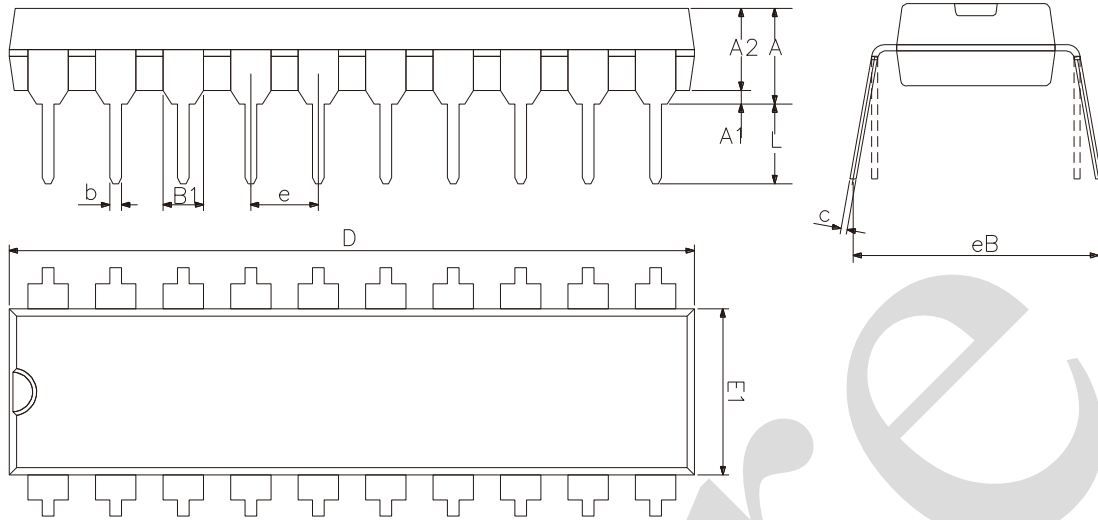

2023/12/A	Dimensions In Millimeters		
	Symbol	Min	Max
	A	3.60	5.33
	A1	0.51	—
	A2	3.20	3.60
	b	0.36	0.53
	B1	1.52	
	c	0.204	0.36
	D	25.70	26.54
	E1	6.20	6.75
	e	2.54	
	eB	7.62	9.30
	L	3.00	3.60



5.2、SOP20

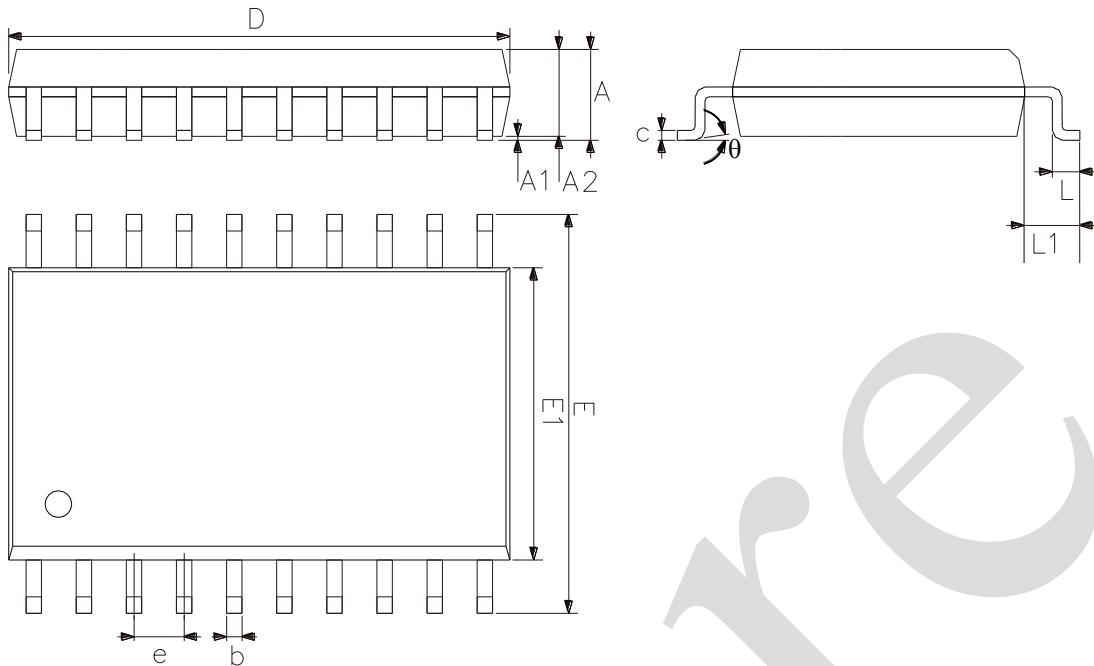

2023/12/A	Dimensions In Millimeters	
Symbol	Min.	Max.
A	2.47	2.65
A1	0.05	0.30
A2	2.20	2.44
b	0.35	0.50
c	0.15	0.30
D	12.54	12.94
E	10.00	10.60
E1	7.30	7.70
e	1.27	
L	0.40	1.05
L1	1.30	1.50
θ	0°	8°



5.3、TSSOP20

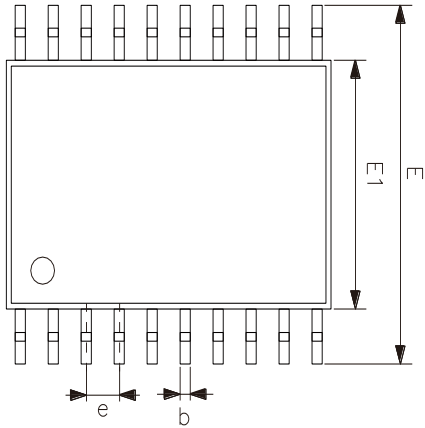
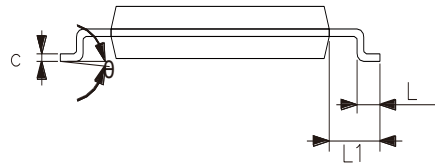
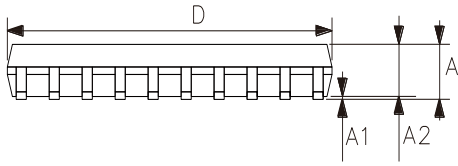

2023/12/A	Dimensions In Millimeters	
Symbol	Min	Max
A	—	1.20
A1	0.05	0.15
A2	0.80	1.05
b	0.19	0.30
c	0.09	0.20
D	6.40	6.60
E1	4.30	4.50
E	6.20	6.60
e	0.65	
L	0.45	0.75
L1	1.00	
θ	0°	8°



6、 Statements And Notes

6.1、 The name and content of Hazardous substances or Elements in the product

Part name	Hazardous substances or Elements									
	Lead and lead compounds	Mercury and mercury compounds	Cadmium and cadmium compounds	Hexavalent chromium compounds	Polybrominated biphenyls	Polybrominated biphenyl ethers	Dibutyl phthalate	Butylbenzyl phthalate	Di-2-ethylhexyl phthalate	Diisobutyl phthalate
Lead frame	○	○	○	○	○	○	○	○	○	○
Plastic resin	○	○	○	○	○	○	○	○	○	○
Chip	○	○	○	○	○	○	○	○	○	○
The lead	○	○	○	○	○	○	○	○	○	○
Plastic sheet installed	○	○	○	○	○	○	○	○	○	○
explanation	○: Indicates that the content of hazardous substances or elements in the detection limit of the following the SJ/T11363-2006 standard. ×: Indicates that the content of hazardous substances or elements exceeding the SJ/T11363-2006 Standard limit requirements.									

6.2、 Notes

We recommend you to read this chapter carefully before using this product.

The information in this chapter is provided for reference only and i-Core disclaims any express or implied warranties, including but not limited to applicability, special application or non-infringement of third party rights.

This product is not suitable for critical equipment such as life-saving, life-sustaining or safety equipment. It is also not suitable for applications that may result in personal injury, death, or serious property or environmental damage due to product malfunction or failure. I-Core will not be liable for any damages incurred by the customers at their own risk for such applications.

The customer is responsible for conducting all necessary tests i-Core's application to avoid failure in the application or the application of the customer's third party users. I-Core does not accept any liability.

The Company reserves the right to change or improve the information published in this chapter at any time. The information in this chapter are subject to change without notice. We recommend the customer to consult our sales staff before purchasing.

Please obtain related materials form i-Core's regular channels and we are not responsible for its content if it is provided by sources other than our company.

In case of any conflict between the Chinese and English version, the version is subject to the Chinese one.