



# AiP74LV245

## Octal Bus Transceiver; 3-State

### Product Specification

**Specification Revision History:**

Version	Date	Description
2025-11-A0	2025-11	New
2026-03-A1	2026-03	Modify the parameters



# Contents

<b>1、 General Description.....</b>	<b>3</b>
<b>2、 Block Diagram And Pin Description .....</b>	<b>5</b>
2.1、 Block Diagram .....	5
2.2、 Pin Configurations.....	6
2.3、 Pin Description .....	6
2.4、 Function Table.....	6
<b>3、 Electrical Parameter .....</b>	<b>7</b>
3.1、 Absolute Maximum Ratings.....	7
3.2、 Recommended Operating Conditions.....	7
3.3、 Electrical Characteristics .....	8
3.3.1、 DC Characteristics 1 .....	8
3.3.2、 DC Characteristics 2 .....	9
3.3.3、 AC Characteristics 1 .....	10
3.3.4、 AC Characteristics 2 .....	11
<b>4、 Testing Circuit .....</b>	<b>12</b>
4.1、 AC Testing Circuit .....	12
4.2、 AC Testing Waveforms.....	12
4.3、 Measurement Points .....	13
4.4、 Test Data .....	13
<b>5、 Package Information .....</b>	<b>14</b>
5.1、 DIP20 .....	14
5.2、 SOP20 .....	15
5.3、 TSSOP20.....	16
<b>6、 Statements And Notes .....</b>	<b>17</b>
6.1、 The name and content of Hazardous substances or Elements in the product .....	17
6.2、 Notes .....	17



## 1、 General Description

The AiP74LV245 is an 8-bit transceiver with 3-state outputs. The device features an output enable ( $\overline{OE}$ ) and send/receive (DIR) for direction control. A HIGH on  $\overline{OE}$  causes the outputs to assume a high-impedance OFF-state.

### Features:

- Operating voltage: 2.0V to 5.5V
- 5.5V tolerant inputs/outputs
- Power-down mode
- Specified from -40°C to +125°C
- Packaging information: DIP20/SOP20/TSSOP20



## Ordering Information:

### Tube packing specifications:

Part number	Packaging form	Marking code	Tube quantity	Boxed tube quantity	Boxed quantity	Notes	Moisture sensitivity level
AiP74LV245DA20.TB	DIP20	74LV245	18 PCS/tube	40 tube/box	720 PCS/box	Dimensions of plastic enclosure: 26.3mm×6.4mm Pin spacing: 2.54mm	-
AiP74LV245SA20.TB	SOP20	74LV245	35 PCS/tube	80 tube/box	2800 PCS/box	Dimensions of plastic enclosure: 12.8mm×7.5mm Pin spacing: 1.27mm	MSL3

### Reel packing specifications:

Part number	Packaging form	Marking code	Reel quantity	Boxed reel quantity	Notes	Moisture sensitivity level
AiP74LV245SA20.TR	SOP20	74LV245	2000 PCS/reel	2000 PCS/box	Dimensions of plastic enclosure: 12.8mm×7.5mm Pin spacing: 1.27mm	MSL3
AiP74LV245TA20.TR	TSSOP20	74LV245	4000 PCS/reel	8000 PCS/box	Dimensions of plastic enclosure: 6.5mm×4.4mm Pin spacing: 0.65mm	MSL3

Note: If the physical information is inconsistent with the ordering information, please refer to the actual product.



## 2、Block Diagram And Pin Description

### 2.1、Block Diagram

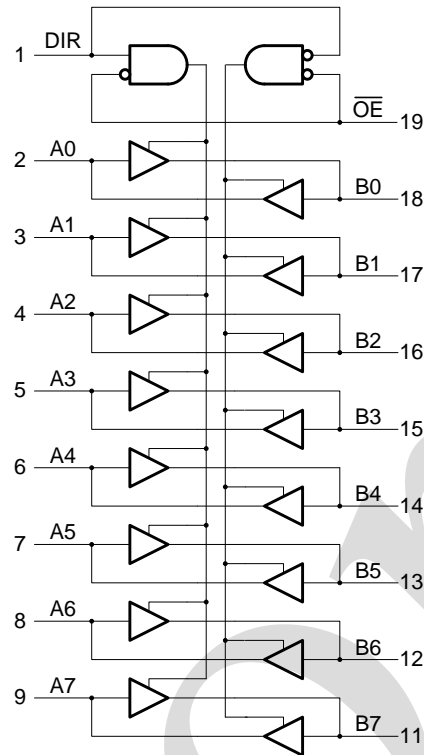

Figure 1. Logic symbol

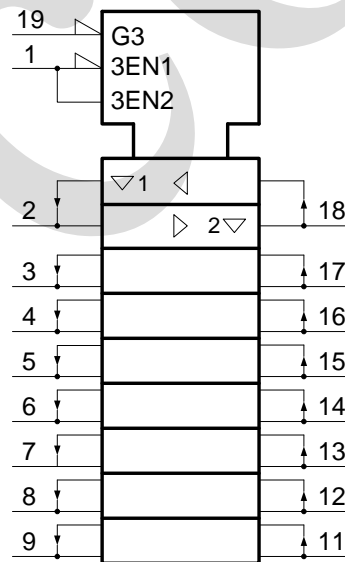
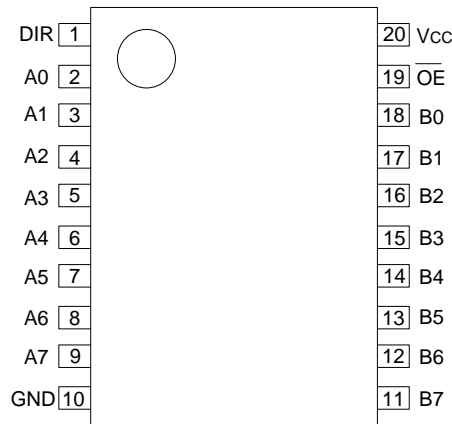

Figure 2. IEC logic symbol



## 2.2、Pin Configurations



## 2.3、Pin Description

Pin No.	Pin Name	Description
1	DIR	direction control
2	A0	data input/output
3	A1	data input/output
4	A2	data input/output
5	A3	data input/output
6	A4	data input/output
7	A5	data input/output
8	A6	data input/output
9	A7	data input/output
10	GND	ground (0V)
11	B7	data input/output
12	B6	data input/output
13	B5	data input/output
14	B4	data input/output
15	B3	data input/output
16	B2	data input/output
17	B1	data input/output
18	B0	data input/output
19	OE	output enable input (active LOW)
20	V <sub>CC</sub>	supply voltage

## 2.4、Function Table

Input		Input/Output	
OE	DIR	A <sub>n</sub>	B <sub>n</sub>
L	L	A=B	input
L	H	input	B=A
H	X	Z	Z

Note: H=HIGH voltage level; L=LOW voltage level; X=don't care; Z=high-impedance OFF-state.



## 3、Electrical Parameter

### 3.1、Absolute Maximum Ratings

(Voltages are referenced to GND (ground=0V), unless otherwise specified.)

Parameter	Symbol	Conditions	Min.	Max.	Unit
supply voltage	$V_{CC}$	-	-0.5	+7.0	V
input clamping current	$I_{IK}$	$V_I < -0.5V$ or $V_I > V_{CC}+0.5V$	-	$\pm 20$	mA
output clamping current	$I_{OK}$	$V_O < -0.5V$ or $V_O > V_{CC}+0.5V$	-	$\pm 50$	mA
output current	$I_O$	$-0.5V < V_O < V_{CC}+0.5V$	-	$\pm 35$	mA
supply current	$I_{CC}$	-	-	70	mA
ground current	$I_{GND}$	-	-70	-	mA
storage temperature	$T_{stg}$	-	-65	+150	°C
total power dissipation	$P_{tot}$	-	-	500	mW
soldering temperature	$T_L$	10s	DIP	245	°C
			SOP/TSSOP	260	
electrostatic discharge	ESD	HBM	2000		V

Note:

[1] Stresses beyond those listed may cause permanent damage to the device. These are stress ratings only and functional operation of the device at these or any other conditions beyond those indicated under “recommended operating conditions” is not implied. Exposure to absolute-maximum-rated conditions for extended periods may affect device reliability.

### 3.2、Recommended Operating Conditions

Parameter	Symbol	Conditions	Min.	Typ.	Max.	Unit
supply voltage	$V_{CC}$	-	2.0	-	5.5	V
input voltage	$V_I$	-	0	-	$V_{CC}$	V
output voltage	$V_O$	-	0	-	$V_{CC}$	V
ambient temperature	$T_{amb}$	-	-40	-	+125	°C
input transition rise and fall rate	$\Delta t/\Delta V$	$V_{CC}=2.3V$ to $2.7V$	-	-	200	ns/V
		$V_{CC}=3.0V$ to $3.6V$	-	-	100	ns/V
		$V_{CC}=4.5V$ to $5.5V$	-	-	20	ns/V

Note: The LV is guaranteed to function down to  $V_{CC}=1.0V$  (input levels GND or  $V_{CC}$ ); DC characteristics are guaranteed from  $V_{CC}=1.2V$  to  $V_{CC}=5.5V$ .



## 3.3、Electrical Characteristics

### 3.3.1、DC Characteristics 1

( $T_{amb}=-40^{\circ}\text{C}$  to  $+85^{\circ}\text{C}$ , voltages are referenced to GND (ground=0V), unless otherwise specified.)

Parameter	Symbol	Conditions	Min.	Typ.	Max.	Unit	
HIGH-level input voltage	$V_{IH}$	$V_{CC}=2V$	1.5	-	-	V	
		$V_{CC}=2.3V$ to $2.7V$	$0.7 \times V_{CC}$	-	-	V	
		$V_{CC}=3.0V$ to $3.6V$	$0.7 \times V_{CC}$	-	-	V	
		$V_{CC}=4.5V$ to $5.5V$	$0.7 \times V_{CC}$	-	-	V	
LOW-level input voltage	$V_{IL}$	$V_{CC}=2V$	-	-	0.5	V	
		$V_{CC}=2.3V$ to $2.7V$	-	-	$0.3 \times V_{CC}$	V	
		$V_{CC}=3.0V$ to $3.6V$	-	-	$0.3 \times V_{CC}$	V	
		$V_{CC}=4.5V$ to $5.5V$	-	-	$0.3 \times V_{CC}$	V	
HIGH-level output voltage	$V_{OH}$	$V_I = V_{IH}$ or $V_{IL}$	$I_O=-50\mu A$ ; $V_{CC}=2V$ to $5.5V$	$V_{CC}$ -0.1	-	-	V
			$I_O=-2mA$ ; $V_{CC}=2.3V$	2	-	-	V
			$I_O=-8mA$ ; $V_{CC}=3.0V$	2.48	-	-	V
			$I_O=-16mA$ ; $V_{CC}=4.5V$	3.8	-	-	V
LOW-level output voltage	$V_{OL}$	$V_I = V_{IH}$ or $V_{IL}$	$I_O=50\mu A$ ; $V_{CC}=2V$ to $5.5V$	-	-	0.1	V
			$I_O=2mA$ ; $V_{CC}=2.3V$	-	-	0.4	V
			$I_O=8mA$ ; $V_{CC}=3.0V$	-	-	0.44	V
			$I_O=16mA$ ; $V_{CC}=4.5V$	-	-	0.55	V
input leakage current	$I_I$	$V_I=V_{CC}$ or GND; $V_{CC}=0V$ to $5.5V$	-	-	$\pm 1$	$\mu A$	
OFF-state output current	$I_{OZ}$	$V_I=V_{IH}$ or $V_{IL}$ ; $V_O=$ GND to $5.5V$ ; $V_{CC}=5.5V$	-	-	$\pm 2.5$	$\mu A$	
power-off leakage current	$I_{OFF}$	$V_I$ or $V_O=$ GND to $5.5V$ ; $V_{CC}=0V$ to $5.5V$	-	-	5	$\mu A$	
supply current	$I_{CC}$	$V_I=V_{CC}$ or GND; $I_O=0A$ ; $V_{CC}=5.5V$	-	-	20	$\mu A$	

Note: All typical values are measured at  $T_{amb}=25^{\circ}\text{C}$



## 3.3.2、DC Characteristics 2

( $T_{amb}=-40^{\circ}\text{C}$  to  $+125^{\circ}\text{C}$ , voltages are referenced to GND (ground=0V), unless otherwise specified.)

Parameter	Symbol	Conditions	Min.	Typ.	Max.	Unit	
HIGH-level input voltage	$V_{IH}$	$V_{CC}=2\text{V}$	1.5	-	-	V	
		$V_{CC}=2.3\text{V}$ to $2.7\text{V}$	$0.7 \times V_{CC}$	-	-	V	
		$V_{CC}=3.0\text{V}$ to $3.6\text{V}$	$0.7 \times V_{CC}$	-	-	V	
		$V_{CC}=4.5\text{V}$ to $5.5\text{V}$	$0.7 \times V_{CC}$	-	-	V	
LOW-level input voltage	$V_{IL}$	$V_{CC}=2\text{V}$	-	-	0.5	V	
		$V_{CC}=2.3\text{V}$ to $2.7\text{V}$	-	-	$0.3 \times V_{CC}$	V	
		$V_{CC}=3.0\text{V}$ to $3.6\text{V}$	-	-	$0.3 \times V_{CC}$	V	
		$V_{CC}=4.5\text{V}$ to $5.5\text{V}$	-	-	$0.3 \times V_{CC}$	V	
HIGH-level output voltage	$V_{OH}$	$V_I = V_{IH}$ or $V_{IL}$	$I_O=-50\mu\text{A}; V_{CC}=2\text{V}$ to $5.5\text{V}$	$V_{CC}-0.1$	-	-	V
			$I_O=-2\text{mA}; V_{CC}=2.3\text{V}$	2	-	-	V
			$I_O=-8\text{mA}; V_{CC}=3.0\text{V}$	2.48	-	-	V
			$I_O=-16\text{mA}; V_{CC}=4.5\text{V}$	3.8	-	-	V
LOW-level output voltage	$V_{OL}$	$V_I = V_{IH}$ or $V_{IL}$	$I_O=50\mu\text{A}; V_{CC}=2\text{V}$ to $5.5\text{V}$	-	-	0.1	V
			$I_O=2\text{mA}; V_{CC}=2.3\text{V}$	-	-	0.4	V
			$I_O=8\text{mA}; V_{CC}=3.0\text{V}$	-	-	0.44	V
			$I_O=16\text{mA}; V_{CC}=4.5\text{V}$	-	-	0.55	V
input leakage current	$I_I$	$V_I=V_{CC}$ or GND; $V_{CC}=0\text{V}$ to $5.5\text{V}$	-	-	$\pm 1$	$\mu\text{A}$	
OFF-state output current	$I_{OZ}$	$V_I=V_{IH}$ or $V_{IL}; V_O=$ GND to $5.5\text{V}; V_{CC}=5.5\text{V}$	-	-	$\pm 2.5$	$\mu\text{A}$	
power-off leakage current	$I_{OFF}$	$V_I$ or $V_O=$ GND to $5.5\text{V}; V_{CC}=0\text{V}$ to $5.5\text{V}$	-	-	5	$\mu\text{A}$	
supply current	$I_{CC}$	$V_I=V_{CC}$ or GND; $I_O=0\text{A}; V_{CC}=5.5\text{V}$	-	-	20	$\mu\text{A}$	

Note: All typical values are measured at  $T_{amb}=25^{\circ}\text{C}$



### 3.3.3、 AC Characteristics 1

( $T_{amb}=-40^{\circ}\text{C}$  to  $+85^{\circ}\text{C}$ ,  $\text{GND}=0\text{V}$ ;  $t_r=t_f=3\text{ns}$ ;  $C_L=15\text{pF}$  or  $50\text{pF}$ ;  $R_L=500\Omega$ , unless otherwise specified.)

Parameter	Symbol	Conditions	Min.	Typ.	Max.	Unit	
An, Bn to Bn, An; propagation delay	$t_{PHL}/t_{PLH}$	see Figure 4,5	$V_{CC}=2.3\text{V}$ to $2.7\text{V}$ ; $C_L=15\text{pF}$	1	-	15	ns
			$V_{CC}=2.3\text{V}$ to $2.7\text{V}$ ; $C_L=50\text{pF}$	1	-	18	ns
			$V_{CC}=3\text{V}$ to $3.6\text{V}$ ; $C_L=15\text{pF}$	1	-	10	ns
			$V_{CC}=3\text{V}$ to $3.6\text{V}$ ; $C_L=50\text{pF}$	1	-	13.5	ns
			$V_{CC}=4.5\text{V}$ to $5.5\text{V}$ ; $C_L=15\text{pF}$	1	-	6.5	ns
			$V_{CC}=4.5\text{V}$ to $5.5\text{V}$ ; $C_L=50\text{pF}$	1	-	8.5	ns
$\overline{\text{OE}}$ to An, Bn; 3-state output enable time	$t_{PZH}/t_{PZL}$	see Figure 4,5	$V_{CC}=2.3\text{V}$ to $2.7\text{V}$ ; $C_L=15\text{pF}$	1	-	22	ns
			$V_{CC}=2.3\text{V}$ to $2.7\text{V}$ ; $C_L=50\text{pF}$	1	-	26	ns
			$V_{CC}=3\text{V}$ to $3.6\text{V}$ ; $C_L=15\text{pF}$	1	-	15.5	ns
			$V_{CC}=3\text{V}$ to $3.6\text{V}$ ; $C_L=50\text{pF}$	1	-	19	ns
			$V_{CC}=4.5\text{V}$ to $5.5\text{V}$ ; $C_L=15\text{pF}$	1	-	10	ns
			$V_{CC}=4.5\text{V}$ to $5.5\text{V}$ ; $C_L=50\text{pF}$	1	-	12	ns
$\overline{\text{OE}}$ to An, Bn; 3-state output disable time	$t_{PHZ}/t_{PLZ}$	see Figure 4,5	$V_{CC}=2.3\text{V}$ to $2.7\text{V}$ ; $C_L=15\text{pF}$	1	-	20	ns
			$V_{CC}=2.3\text{V}$ to $2.7\text{V}$ ; $C_L=50\text{pF}$	1	-	25	ns
			$V_{CC}=3\text{V}$ to $3.6\text{V}$ ; $C_L=15\text{pF}$	1	-	19.5	ns
			$V_{CC}=3\text{V}$ to $3.6\text{V}$ ; $C_L=50\text{pF}$	1	-	22	ns
			$V_{CC}=4.5\text{V}$ to $5.5\text{V}$ ; $C_L=15\text{pF}$	1	-	14.2	ns
			$V_{CC}=4.5\text{V}$ to $5.5\text{V}$ ; $C_L=50\text{pF}$	1	-	16	ns

Note:

[1] Unless otherwise stated, all typical values are measured at  $T_{amb}=25^{\circ}\text{C}$ .

[2] Typical values are measured at  $V_{CC}=3.3\text{V}$ .

[3]  $C_{PD}$  is used to determine the dynamic power dissipation ( $P_D$  in uW).

$$P_D = C_{PD} \times V_{CC}^2 \times f_i + \sum (C_L \times V_{CC}^2 \times f_o) \text{ where:}$$

$f_i$ =input frequency in MHz;

$f_o$ =output frequency in MHz;

$C_L$ =output load capacitance in pF;

$V_{CC}$ =supply voltage in V;

$\sum (C_L \times V_{CC}^2 \times f_o)$ =sum of outputs.



## 3.3.4、AC Characteristics 2

( $T_{amb}=-40^{\circ}\text{C}$  to  $+125^{\circ}\text{C}$ ,  $GND=0\text{V}$ ;  $t_r=t_f=3\text{ns}$ ;  $C_L=15\text{pF}$  or  $50\text{pF}$ ;  $R_L=500\Omega$ , unless otherwise specified.)

Parameter	Symbol	Conditions	Min.	Typ.	Max.	Unit	
An, Bn to Bn, An; propagation delay	$t_{PHL}/t_{PLH}$	see Figure 4,5	$V_{CC}=2.3\text{V}$ to $2.7\text{V}$ ; $C_L=15\text{pF}$	1	-	17	ns
			$V_{CC}=2.3\text{V}$ to $2.7\text{V}$ ; $C_L=50\text{pF}$	1	-	21	ns
			$V_{CC}=3\text{V}$ to $3.6\text{V}$ ; $C_L=15\text{pF}$	1	-	11	ns
			$V_{CC}=3\text{V}$ to $3.6\text{V}$ ; $C_L=50\text{pF}$	1	-	14.5	ns
			$V_{CC}=4.5\text{V}$ to $5.5\text{V}$ ; $C_L=15\text{pF}$	1	-	7	ns
			$V_{CC}=4.5\text{V}$ to $5.5\text{V}$ ; $C_L=50\text{pF}$	1	-	9	ns
$\overline{\text{OE}}$ to An, Bn; 3-state output enable time	$t_{pZH}/t_{pZL}$	see Figure 4,5	$V_{CC}=2.3\text{V}$ to $2.7\text{V}$ ; $C_L=15\text{pF}$	1	-	24	ns
			$V_{CC}=2.3\text{V}$ to $2.7\text{V}$ ; $C_L=50\text{pF}$	1	-	28	ns
			$V_{CC}=3\text{V}$ to $3.6\text{V}$ ; $C_L=15\text{pF}$	1	-	16.5	ns
			$V_{CC}=3\text{V}$ to $3.6\text{V}$ ; $C_L=50\text{pF}$	1	-	20	ns
			$V_{CC}=4.5\text{V}$ to $5.5\text{V}$ ; $C_L=15\text{pF}$	1	-	10.5	ns
			$V_{CC}=4.5\text{V}$ to $5.5\text{V}$ ; $C_L=50\text{pF}$	1	-	12.5	ns
$\overline{\text{OE}}$ to An, Bn; 3-state output disable time	$t_{pHZ}/t_{pLZ}$	see Figure 4,5	$V_{CC}=2.3\text{V}$ to $2.7\text{V}$ ; $C_L=15\text{pF}$	1	-	22	ns
			$V_{CC}=2.3\text{V}$ to $2.7\text{V}$ ; $C_L=50\text{pF}$	1	-	27	ns
			$V_{CC}=3\text{V}$ to $3.6\text{V}$ ; $C_L=15\text{pF}$	1	-	20.5	ns
			$V_{CC}=3\text{V}$ to $3.6\text{V}$ ; $C_L=50\text{pF}$	1	-	23	ns
			$V_{CC}=4.5\text{V}$ to $5.5\text{V}$ ; $C_L=15\text{pF}$	1	-	14.7	ns
			$V_{CC}=4.5\text{V}$ to $5.5\text{V}$ ; $C_L=50\text{pF}$	1	-	16.5	ns

Note:

[1] Unless otherwise stated, all typical values are measured at  $T_{amb}=25^{\circ}\text{C}$ .

[2] Typical values are measured at  $V_{CC}=3.3\text{V}$ .



### 4、 Testing Circuit

#### 4.1、 AC Testing Circuit

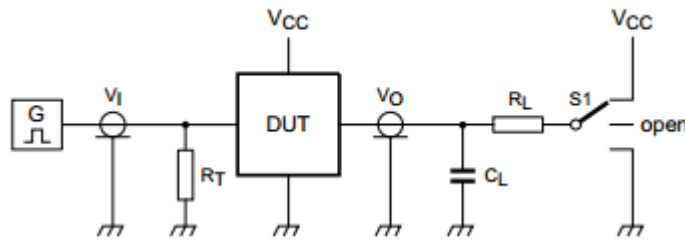

Figure 3. Load circuit for switching times

Definitions for test circuit:

$R_L$ =Load resistance.

$C_L$ =Load capacitance including jig and probe capacitance.

$R_T$ =Termination resistance should be equal to the output impedance  $Z_o$  of the pulse generator.

#### 4.2、 AC Testing Waveforms

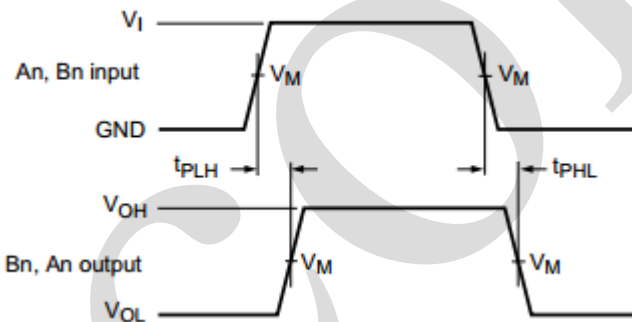

Figure 4. The input (An, Bn) to output (Bn, An) propagation delays

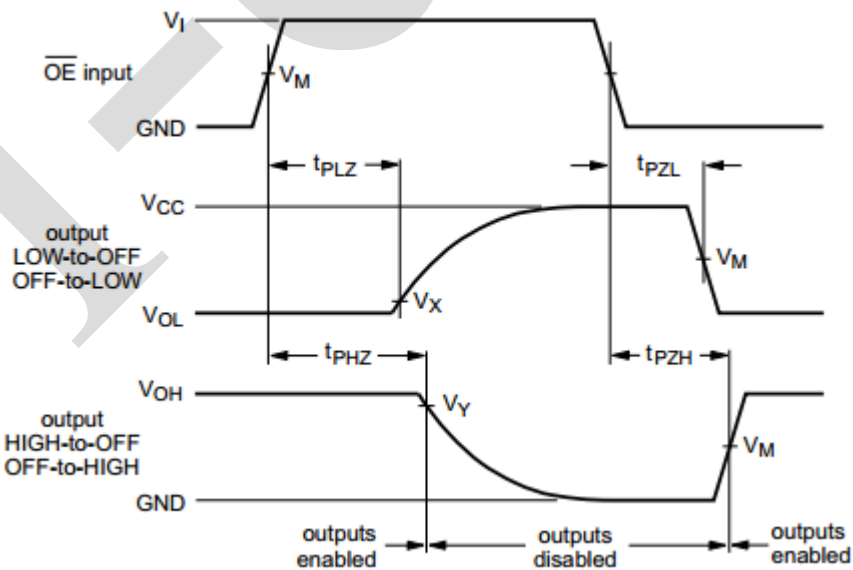

Figure 5. Enable and disable times



### 4.3、Measurement Points

Supply voltage	Input	Output		
$V_{CC}$	$V_M$	$V_M$	$V_X$	$V_Y$
2.7V to 5.5V	$0.5 \times V_{CC}$	$0.5 \times V_{CC}$	$V_{OL}+0.3V$	$V_{OH}-0.3V$

### 4.4、Test Data

Supply voltage	Input		Load		S1 position		
$V_{CC}$	$V_I$	$t_r, t_f$	$C_L$	$R_L$	$t_{PHL}, t_{PLH}$	$t_{PZH}, t_{PHZ}$	$t_{PZL}, t_{PLZ}$
2.7V to 5.5V	GND to $V_{CC}$	3ns	15pF, 50pF	1k $\Omega$	open	GND	$V_{CC}$



## 5、Package Information

### 5.1、DIP20

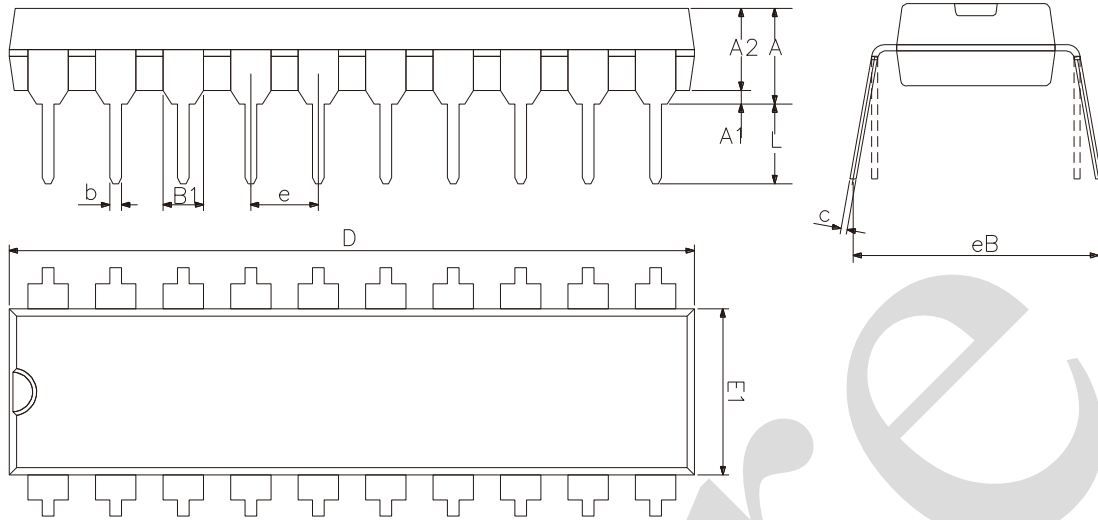

2023/12/A	Dimensions In Millimeters		
	Symbol	Min	Max
	A	3.60	5.33
	A1	0.51	—
	A2	3.20	3.60
	b	0.36	0.53
	B1	1.52	
	c	0.204	0.36
	D	25.70	26.54
	E1	6.20	6.75
	e	2.54	
	eB	7.62	9.30
	L	3.00	3.60



## 5.2、SOP20

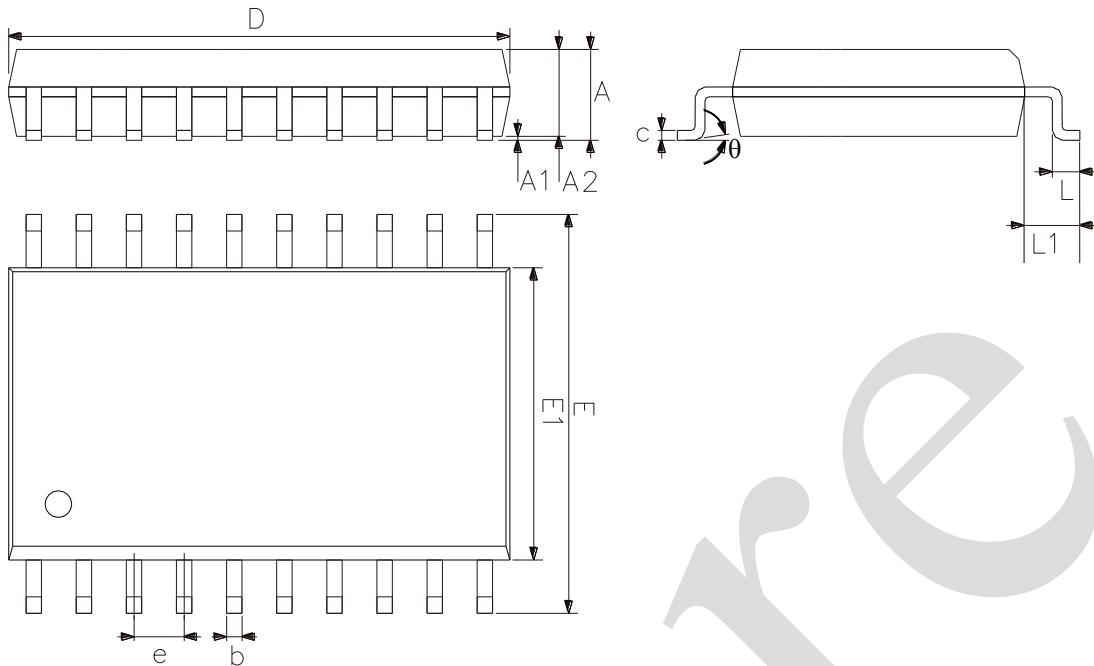

2023/12/A	Dimensions In Millimeters	
Symbol	Min.	Max.
A	2.47	2.65
A1	0.05	0.30
A2	2.20	2.44
b	0.35	0.50
c	0.15	0.30
D	12.54	12.94
E	10.00	10.60
E1	7.30	7.70
e	1.27	
L	0.40	1.05
L1	1.30	1.50
$\theta$	0°	8°



## 5.3、TSSOP20

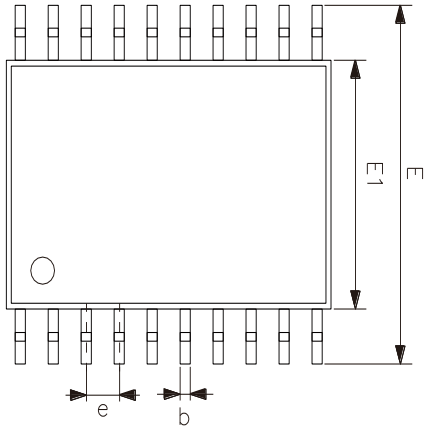
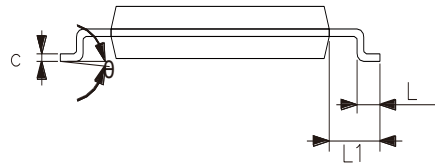
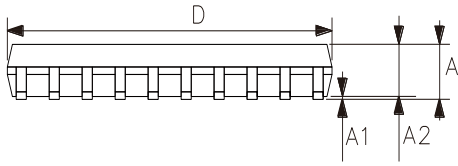

2023/12/A	Dimensions In Millimeters	
Symbol	Min	Max
A	—	1.20
A1	0.05	0.15
A2	0.80	1.05
b	0.19	0.30
c	0.09	0.20
D	6.40	6.60
E1	4.30	4.50
E	6.20	6.60
e	0.65	
L	0.45	0.75
L1	1.00	
$\theta$	0°	8°



## 6、 Statements And Notes

### 6.1、 The name and content of Hazardous substances or Elements in the product

Part name	Hazardous substances or Elements									
	Lead and lead compounds	Mercury and mercury compounds	Cadmium and cadmium compounds	Hexavalent chromium compounds	Polybrominated biphenyls	Polybrominated biphenyl ethers	Dibutyl phthalate	Butylbenzyl phthalate	Di-2-ethylhexyl phthalate	Diisobutyl phthalate
Lead frame	○	○	○	○	○	○	○	○	○	○
Plastic resin	○	○	○	○	○	○	○	○	○	○
Chip	○	○	○	○	○	○	○	○	○	○
The lead	○	○	○	○	○	○	○	○	○	○
Plastic sheet installed	○	○	○	○	○	○	○	○	○	○
explanation	○: Indicates that the content of hazardous substances or elements in the detection limit of the following the SJ/T11363-2006 standard. ×: Indicates that the content of hazardous substances or elements exceeding the SJ/T11363-2006 Standard limit requirements.									

### 6.2、 Notes

We recommend you to read this chapter carefully before using this product.

The information in this chapter is provided for reference only and i-Core disclaims any express or implied warranties, including but not limited to applicability, special application or non-infringement of third party rights.

This product is not suitable for critical equipment such as life-saving, life-sustaining or safety equipment. It is also not suitable for applications that may result in personal injury, death, or serious property or environmental damage due to product malfunction or failure. I-Core will not be liable for any damages incurred by the customers at their own risk for such applications.

The customer is responsible for conducting all necessary tests i-Core's application to avoid failure in the application or the application of the customer's third party users. I-Core does not accept any liability.

The Company reserves the right to change or improve the information published in this chapter at any time. The information in this chapter are subject to change without notice. We recommend the customer to consult our sales staff before purchasing.

Please obtain related materials form i-Core's regular channels and we are not responsible for its content if it is provided by sources other than our company.

In case of any conflict between the Chinese and English version, the version is subject to the Chinese one.